



PENRITH
CITY COUNCIL

DRIVEWAY STANDARDS AND SPECIFICATIONS

CONDITIONS GOVERNING DRIVEWAYS

Driveways and foot paving construction may only be carried out by property owners, or accredited licensed contractors, subject to the following conditions.

1. No work is to start on Council property until a 'Driveway Application' is lodged and received by Council. Failure to do so will incur infringement notices and fines.
2. Council will not be held responsible for any Public Risk Claims or otherwise, arising from incorrectly installed or unapproved footpath crossings or associated works.
3. Workcover approved barriers, for the protection of the public, must be erected and maintained at any worksite on Council owned or managed property.
4. The contractor/owner is responsible for all damage caused to any public utility located in the footway/road area that is damaged as a result of work performed.
5. Telstra/NBN manholes or pits will not be accepted within vehicle driveways. You are therefore advised to take into account these pits/manholes prior to construction. Council will not accept driveway applications that incorporate or impact on Telstra manholes/pits without written permission, i.e. Clearance from Telstra.
6. All crossings must have the written approval from other Public Utilities, should their service be required to be relocated or remain in the crossing area. It is the owner's responsibility to contact the relevant authority before any concrete is poured. A fee may be applied by the Authority concerned for this service.
7. Proposed vehicle crossings must be located a minimum of 1 metre from storm water drainage pits, Integral/Telstra poles and electrical boxes in residential areas, 2 metres in industrial areas, and no closer than 6 metres to the kerb tangent point near street corners.
8. All street trees must have an appropriate protection zone from the edge of any driveway to ensure any concrete structure does not affect the structural root zone of the tree. A minimum of 1.5m clearance is required but can vary depending on tree species.
9. Council is responsible for any future restoration work in plain grey concrete only, and the use of non-standard materials may require owners to meet any additional cost or to carry out the work themselves of any work by Public Authorities.
10. All stormwater pipes and outlets are to be relocated clear and are not be located within the driveway/layback area.
11. In cases where a new layback is required at a different location, approval will only be granted conditional on the unused layback being restored at the same time, unless both are to be utilised.
12. For driveways to properties which are lower than the road surface, a cross sectional plan is to be submitted with the application, and an onsite meeting with Council's infrastructure Officer is to be arranged, prior to any work commencing.

Inspections

All driveways and associated works are to be inspected when the formwork, steel, chairs, sand and pins are in place. Bookings for inspections are to be made by contacting Council's Asset Management Department on (02) 4732 7777 prior to noon on the previous business day.

Inspections are carried out anytime between 7-10am. Although we try to make accommodations for various circumstances Council cannot guarantee any specific time for inspection. It is the inspector's schedule which will determine the exact time the inspection is carried out.

Upon inspection, if the work is constructed to Council's satisfaction, an inspection certificate will be issued. It is the property owner/contractors' responsibility to check that approval has been granted. If the inspection certificate cannot be located, Council's Asset Management Department must be contacted before pouring on Council's property.

Any persons carrying out unauthorised work without an application being lodged will incur fines or default fee as defined under the Local Government Act. Council officers can order the removal of any concrete or other material that has been completed without approval at the owners/contractors expense.

DRIVEWAY AND LAYBACK SPECIFICATION

Standard requirements

1. Sand, or a similar fine-grained material, to a compacted depth of 30mm is to be placed under concrete.
2. When lapping fabric sheets ensure a minimum of one grid plus 25mm is allowed and sheets tied together.
3. Steel mesh is to be firmly supported on bar chairs at a maximum spacing of 1.2m, and shall have a minimum concrete cover of 40mm
4. A maximum grade of 12.5% (1:8) with a minimum grade of 4% is allowed over the first 3 metres from the layback (where possible). If not possible an onsite meeting with Council's Engineering Co-ordinator is required.
5. A maximum crossfall of 5%.
6. Where it is not possible to have the finished driveway level with the existing footway, then the footway is to be graded to a maximum grade of 1:14 to meet the new driveway. The reinstatement of concrete footpaving if damaged or removed is the property owner's responsibility to have reinstated.
7. A minimum concrete strength of FC25MPa to AS 3600.
8. A movement control joint is to be placed at the property boundary. Full depth mastic or similar is also to be used at the layback joint.
9. If a new driveway does not align with an existing layback, either a new layback must be provided or an existing layback modified to suit the proposed driveway. Kerb and gutter that is to be removed must be completely removed from lip line to back of kerb. New kerb and gutter and/or laybacks are to be dowelled into existing kerb and gutter. Any damage to the road pavement must be repaired at the owners/contractors expense.
10. When reconstructing laybacks and/or K&G a sub-base of at least 200mm compacted thickness on a compacted sub-grade shall be provided in accordance with Council's Engineering Guidelines for Subdivision and Development Works (pt2).
11. All driveways are to be sited perpendicular (90 deg) to the kerb. Sides may be equally angled outwards from the boundary, but not inwards.
12. Types of concrete allowed on Council owned property are: plain/coloured/stencil concrete; pavers. The use of stamped, exposed aggregate or pebblecrete is **NOT** allowed on Council owned property.
13. All driveways are to comply with slip resistance classification of pedestrian surfaces materials, AS/NZS 4586.2013; AS/NZS 3661.2.1994. The finished surface must be sufficiently rough so as to ensure safety for pedestrians and other users. The finished surface must **NOT** be finished in a smooth steel float finish. The surface of the driveway must **NOT** be coated with any epoxy type 'paint' or other sealant. These types of surfaces may result in a smooth finish, which can be slippery in wet weather.
14. Concrete slabs without control joints must not exceed 6 metres in any direction or 36 sqm in area.
15. Soil erosion and sedimentation control measures are to be maintained during the entire construction period until the disturbed areas are restored. Council may issue infringement notices including a monetary penalty where the control measures fail to meet minimum standards as required by Council policy and Acts of Law.
16. When the formwork is removed, the excavated area is to be backfilled and levelled to the top of the slab, and made safe for pedestrian traffic. Maintenance of this area over the settlement period is the owner's responsibility.
17. Council cannot guarantee that cracking, settlement, etc of the construction will not occur in the future and will not be held liable for any claims to repair or reconstruct crossings even where Council had originally inspected and approved the work.

New Subdivision release areas

- Driveways from the boundary to the kerb are to be constructed and remain in plain grey concrete only to a maximum width as specified in the DCP i.e. Jordan Springs and Caddens 4.5m wide.
- Where necessary the footpath can be removed to allow the driveway to remain continuous whilst maintaining the existing levels and grades of the footpath. However, either a tooled joint or saw cuts will need to be provided across the driveway at the footpath alignment.
- Where the existing footpath remains, the driveway must be dowelled into both sides with 12mm galvanised dowels as described below.
- Private footpath connections are permitted to be constructed over Council land to connect with Council owned footpaths. However, these will remain under the ownership and responsibility of the property owner to maintain in a satisfactory condition.

Single dwellings/dual occupancy

- Driveways are to be a minimum of 100mm thick with one layer of SL72 reinforcing mesh, supported on chairs, on 30mm of compacted sand or granular base, dowelled into the back of the layback and adjoining footpath with 12mm galvanised dowels (starting 350mm from each side then at 900mm centres). Laybacks shall be poured separately to the crossing.
- Driveways are to be a minimum of 3 metres wide, maximum of 6 metres (unless otherwise stated), for residential areas.

Light commercial/light industrial units/medium density residential (including townhouse units)

- Driveways are to be a minimum of 150mm thick with one layer of SL82 reinforcing mesh, supported on chairs, on 30mm of compacted sand or granular base, dowelled into the back of the layback and adjoining footpath with 12mm galvanised dowels (starting 500mm from each side then at 900mm centres). Laybacks shall be poured separately to the crossing.

Heavy commercial/heavy industrial

- Driveways are to be a minimum 225mm thick with two layers of SL82 reinforcing mesh, supported on chairs, on 30mm of compacted sand or granular base, dowelled into the back of the layback and adjoining footpath with 20mm galvanised dowels (starting 500mm from each side then at 900mm centres). Laybacks shall be poured separately to the crossing.
- Driveways are to be a minimum of 15.5 metres wide (AS 2890.2 – 2002) unless otherwise approved within a development application.
- Concrete strength min 32 Mpa.

Pavers

Council has approved heavy duty pavers for use in residential driveways, subject to the following conditions:

- Pavers must be laid on 30mm bedding sand on 100mm thick concrete with F72 mesh wired, on chairs, on a 30mm compacted sand base, keyed into layback with 12mm galvanised pins starting 350mm from each side then at 900mm centres.
- Pavers are to be laid in accordance with manufacturer's specifications and a minimum of 60mm thick.
- Pavers are to be placed, with a nominal gap between pavers and filled with fine sand or a suitable replacement.
- Owners are responsible for the maintenance of pavers - keeping them true and level at all times.
- Concrete edge restraints must be used to restrain the pavers and the sand.
- Pavers for townhouses and commercial crossings are to be laid on 30mm bedding sand on 100mm concrete with F72 mesh on bar chairs, on a 30mm compacted sand base and dowelled into layback with 20mm galvanised pins starting 500mm from each side at 900mm centres.

Rural crossings

Due to the variances involved in rural areas - with differences in road reserves and table drain widths, a site inspection by Council's Infrastructure Officer may be required before any works commence, to ascertain levels, designs, etc.

- Concrete Pavement – a pavement of 150mm of reinforced concrete on minimum 30mm compacted granular material on a compacted sub-grade. The concrete shall be reinforced with one layer of SL82 mesh with 50mm top cover supported on bar chairs with full depth dowelled expansion key joints at 6m centres and dummy joints at 2m centres. The driveway shall have a minimum cross fall of 2%.
- Asphalt Pavement – a pavement of a minimum 150mm of compacted DGB 20 or a pavement material in accordance with Section 5.1.7. of Councils Engineering Specification for Civil Works on a compacted sub-grade, using a 10 tonne steel wheeled roller, or at the discretion of Council's Engineer with a minimum 25mm AC wearing course or 2 coat seal with a minimum 2% cross fall.

Note: the pavement design is intended for typical residential use. In intended frequency and size for vehicles greater than residential uses the pavement design should reflect the fact.

Pipe crossings

Pipes are to be a minimum of 300mm internal diameter supported by headwalls at either end, on a 100mm sand/cement base. A minimum of 100mm cover is to be provided over the top of the pipe and all drainage levels are to be calculated and checked prior to installation. See attached drawings for construction specifications.

Dish crossings

Are to be constructed as per Council specifications. Dish crossings are to have a crossfall along the length of the table drain in the direction of the water flow. See attached drawings for construction specifications.

Services

Telstra

A minimum 600mm clearance must be maintained from the edge of any proposed driveway to a Telstra asset.

Where Telstra pits/manholes are located in proposed new or reconstructed driveway locations the owner/contractor will need to contact Telstra's Network Integrity Team prior to any construction commencing.

In no circumstance should any party, including owners, developers or contractors modify or tamper with Telstra assets. Should you need to discuss the relocation or modification of a Telstra asset please contact Telstra's Network Integrity Team via phone: 1800 810 443.

Sydney Water

For any Sydney Water asset located within a new driveway, formal approval is required to be obtained from Sydney Water via their Tap In portal. These includes surface features such as hydrants, stop valves and sewer man holes.

Once approved by Sydney Water the written approval or the stamped approved building plans must be provided prior to Council issuing any approval for the driveway works.

Any utility features which remain within the extents of a new driveway must be serviceable and not covered with any material such as concrete, nor shall any colouring (i.e. painting) on the feature be carried out.

For more information please contact Sydney Water directly via phone: 1300 082 746 or via their website: www.sydneywater.com.au/tapin

Endeavour Energy

A minimum 1m clearance is required from the proposed edge of any driveway (1.5m for industrial driveways) to any Endeavour Energy power pole or light post.

Green electrical boxes in residential areas can be as close as 300mm if a protective barrier (i.e. retaining wall) is provided behind the electrical asset.

Other Assets

For any asset not listed above it is the owner/contractors responsibility to contact the service utilities owner for discussion regarding conflicts between proposed driveways and Service Authority assets.

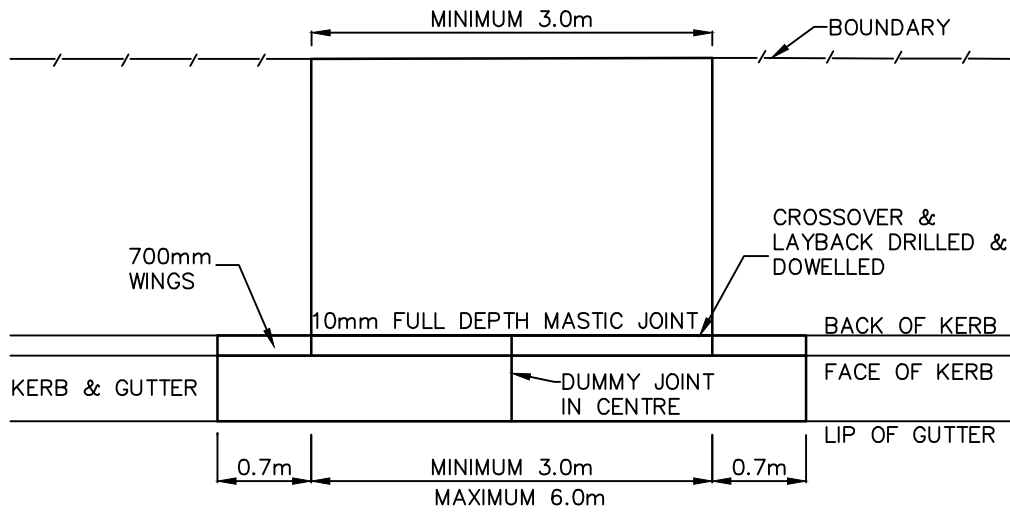

RESIDENTIAL

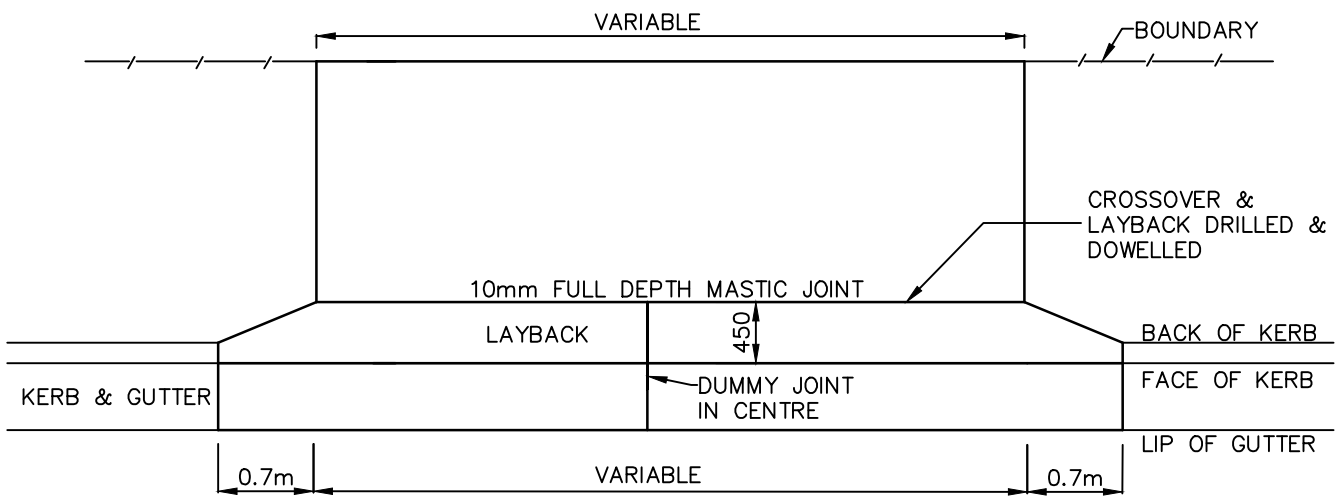

INDUSTRIAL/COMMERCIAL

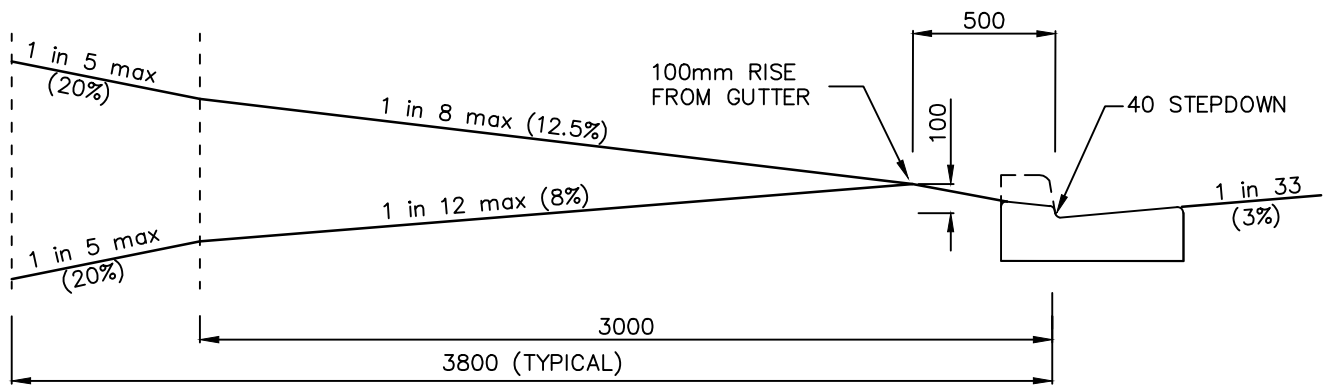

VEHICULAR CROSSING PROFILE – HIGH & LOW LEVEL

DRAWN:

**PENRITH
CITY COUNCIL**

**TYPICAL VEHICULAR
CROSSOVER**

APPROVED:

PLAN No:

SD1004

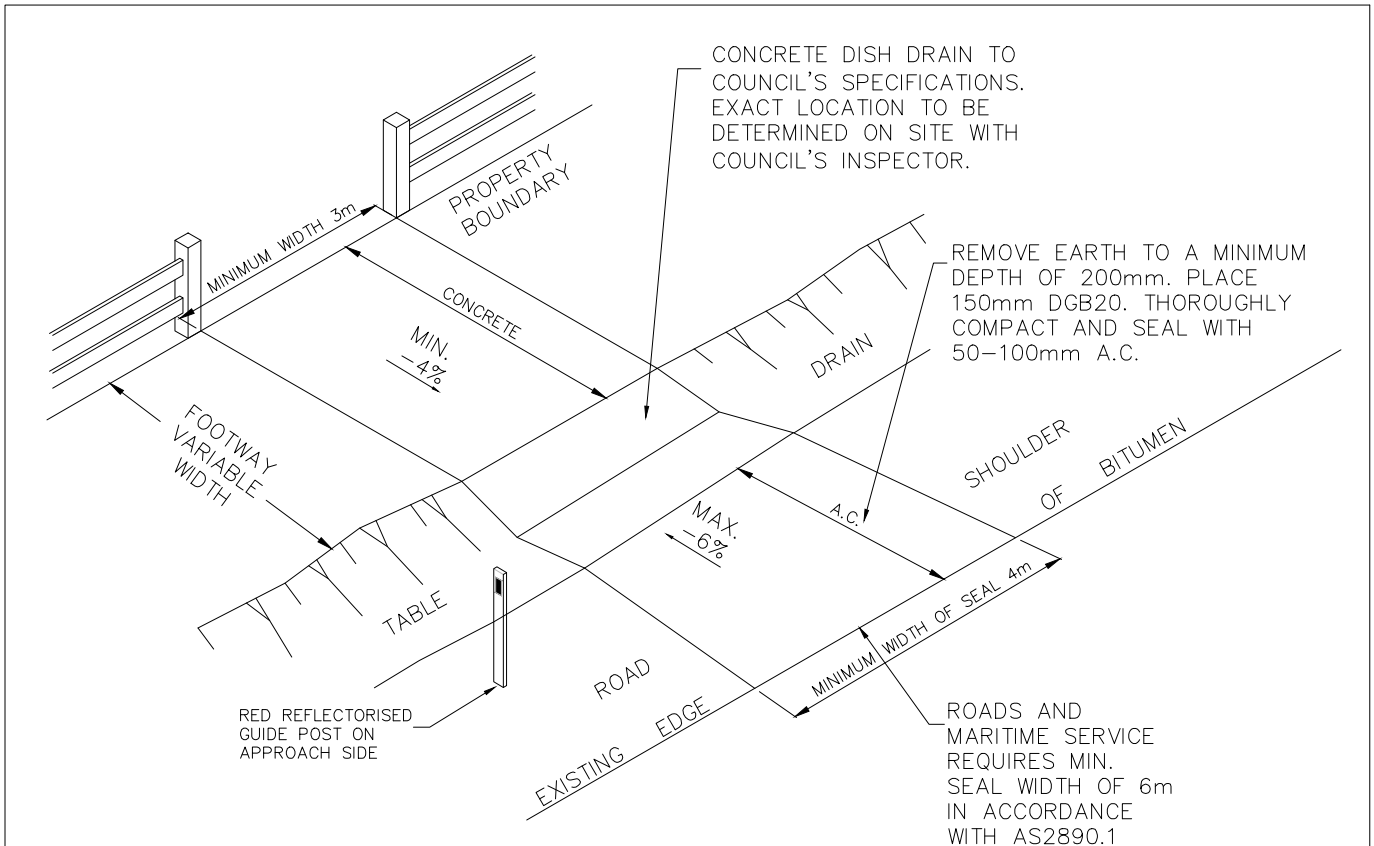

RURAL VEHICULAR CROSSING – TYPE 1

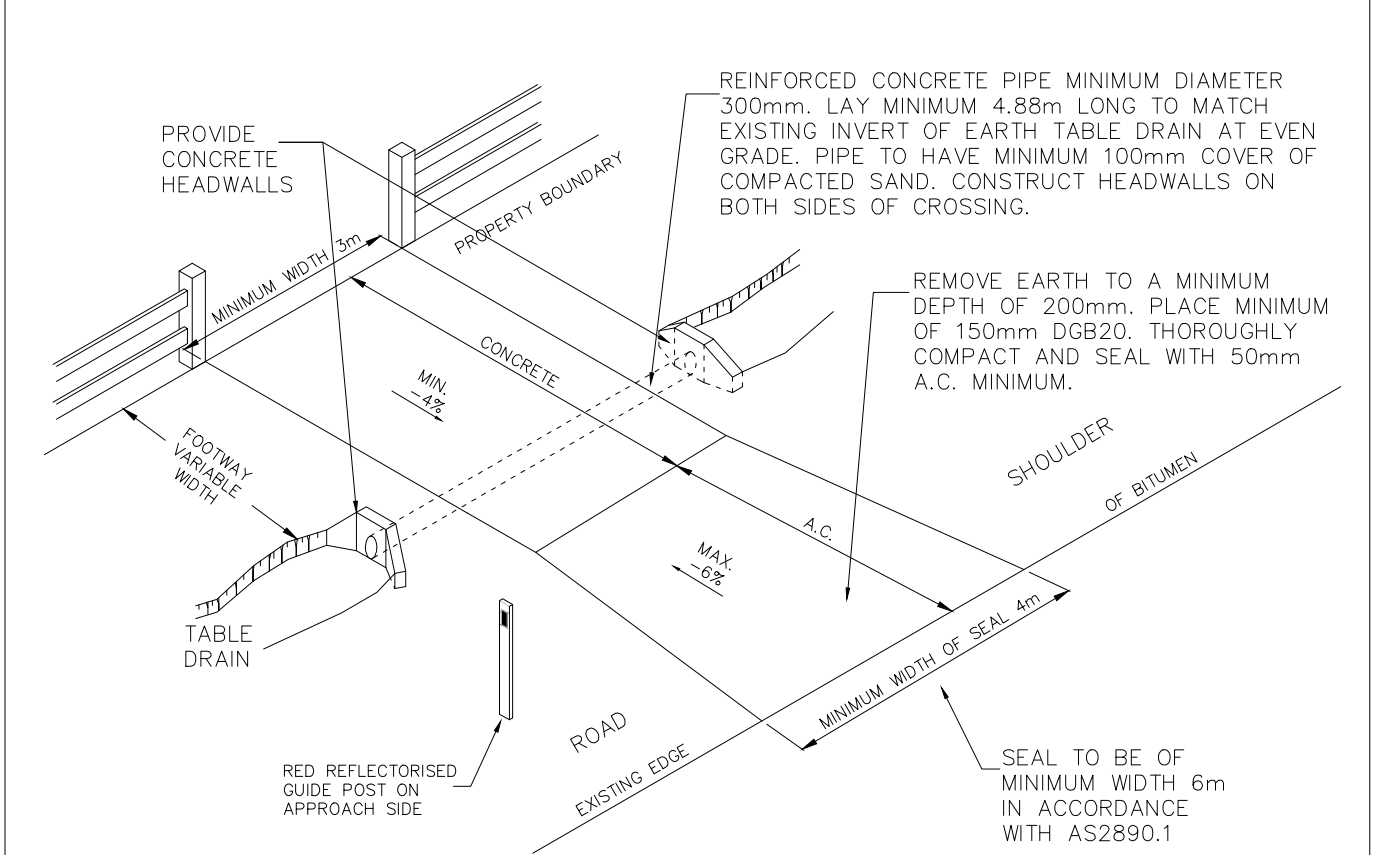

RURAL PIPED VEHICULAR CROSSING – TYPE 2

DRAWN:
E. LAWTON

**PENRITH
CITY COUNCIL**

**RURAL VEHICULAR
CROSSINGS**

APPROVED:

PLAN No:
SD1005

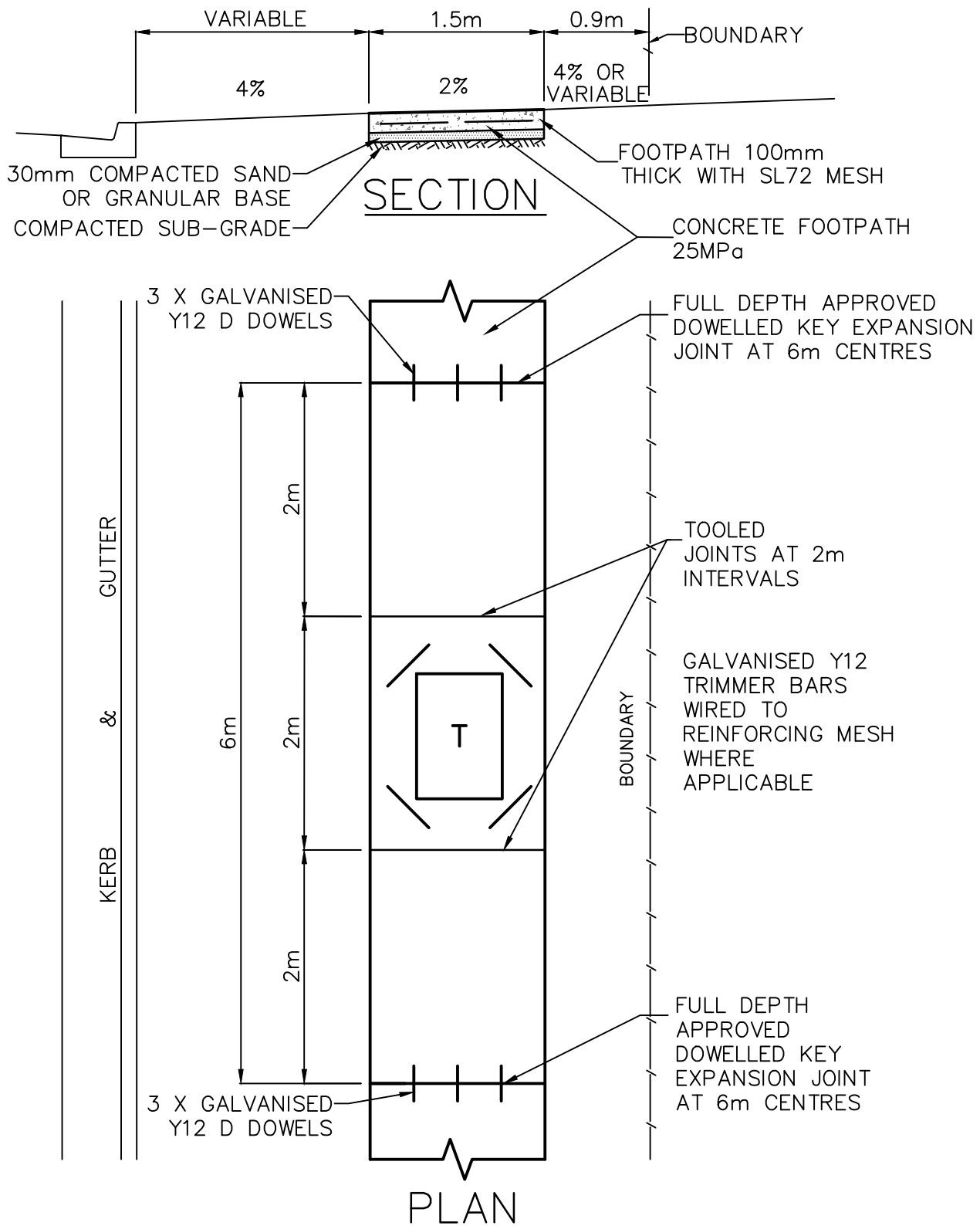

NOTES

1. LONGITUDINAL EDGING IS REQUIRED ON FOOTPATHS. ALL EXPANSION JOINTS SHALL ALSO BE EDGED.
2. THE FOOTPATH SHALL BE FINISHED WITH A BROOM FINISH PERPENDICULAR TO THE DIRECTION OF TRAVEL.
3. FOR MACHINE LAID FOOTPATHS, REFER TO SECTION 7 OF COUNCIL'S CONSTRUCTION SPECIFICATION.
4. FOR CYCLEWAYS, REFER TO SECTION 7 OF COUNCIL'S CONSTRUCTION SPECIFICATION.

DRAWN:
M. WARDA

APPROVED:

PENRITH
CITY COUNCIL

STANDARD FOOTPATH DETAILS

PLAN No.

SD1001

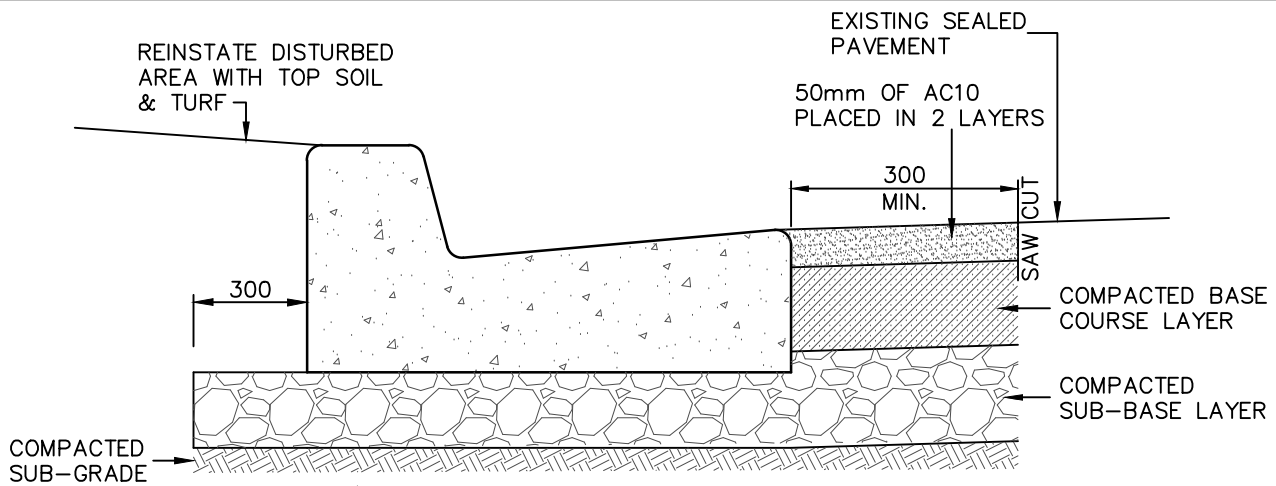

TYPICAL KERB & GUTTER RECONSTRUCTION

REFER NOTE 6 (SHEET 2)

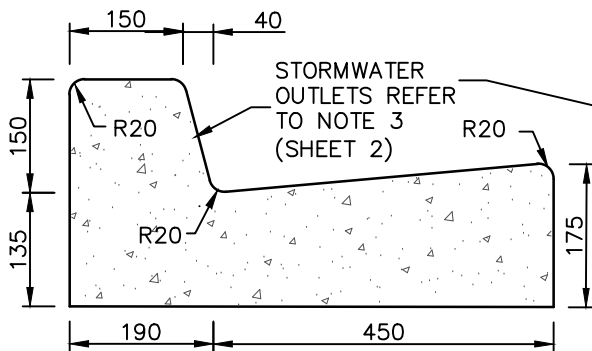

KERB & GUTTER

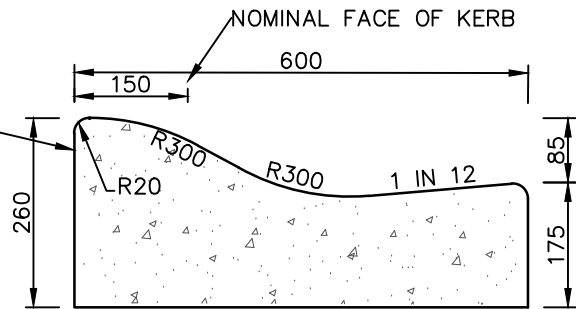

LOW PROFILE ROLL KERB

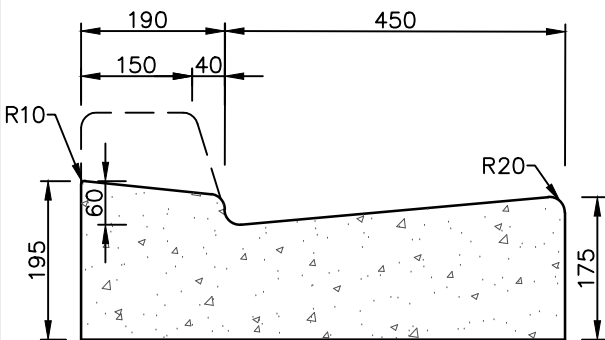

DRIVEWAY LAYBACK – RESIDENTIAL

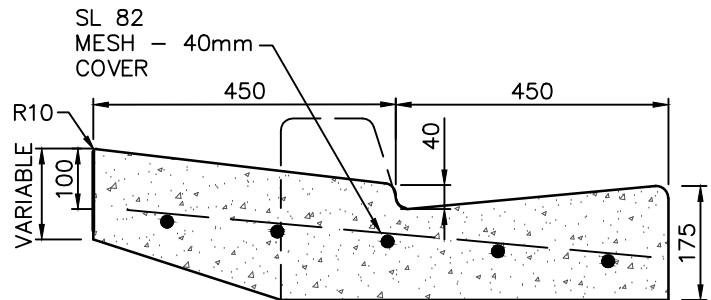

DRIVEWAY LAYBACK – COMMERCIAL & INDUSTRIAL AND LOW LEVEL RESIDENTIAL

DRAWN:

PENRITH CITY COUNCIL

**STANDARD KERB & GUTTER,
LAYBACKS & DISH CROSSING
SHEET 1 OF 2**

APPROVED:

PLAN No:

SD1003/1

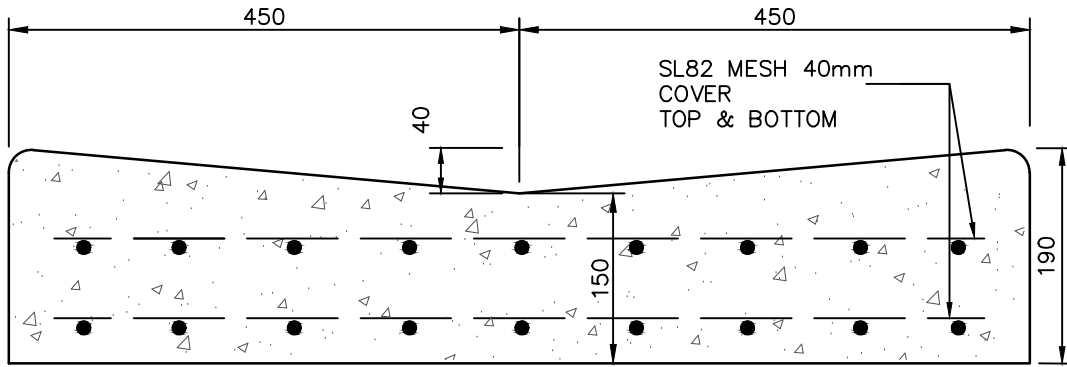

REINFORCED DISH CROSSING

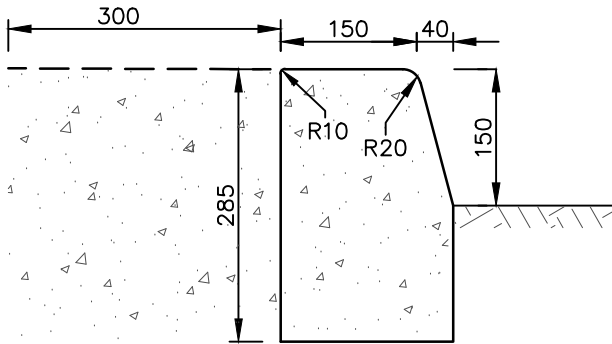

KERB EDGING

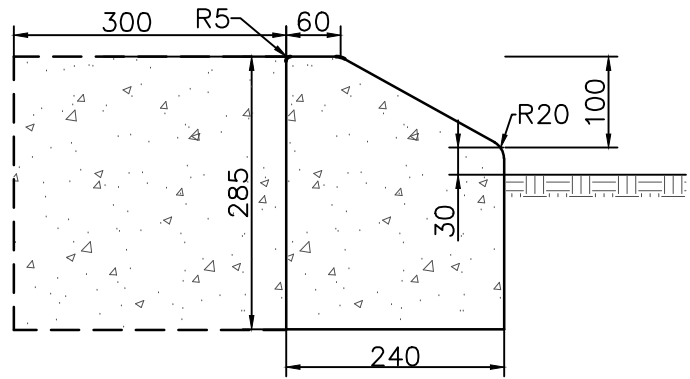

MOUNTABLE KERB

NOTES

1. CONCRETE COMPRESSIVE STRENGTH ($F'c$) AT 28 DAYS, TO BE 25MPa FOR KERB & GUTTER AND DISH CROSSINGS.
2. ROAD SUB-BASE SHALL BE EXTENDED 300mm BEHIND BACK OF KERB WITH THE THICKNESS TO BE NOT LESS THAN THE ROAD PAVEMENT SUB-BASE THICKNESS.
3. GALVANIZED STEEL OR SIMILAR APPROVED STORMWATER KERB ADAPTORS THE FULL HEIGHT OF THE KERB SHALL BE USED. THE KERB OUTLETS ARE TO MATCH THE PROFILE OF THE KERB. SEE SPECIFICATION
4. ALL DIMENSIONS ARE IN MILLIMETERS, UNLESS OTHERWISE STATED.
5. ALL EXPOSED EDGES TO BE ROUNDED TO 20mm RADIUS UNLESS SHOWN OTHERWISE
6. SPECIFICATIONS FOR RECONSTRUCTION WORKS TO BE DETERMINED BY COUNCIL'S ENGINEER.
7. SERVICE CONDUIT LOCATIONS SHALL BE MARKED ON KERB FACE WITH AN APPROVED TOOL OR AS OTHERWISE DIRECTED.

DRAWN:

**PENRITH
CITY COUNCIL**

**STANDARD KERB & GUTTER,
LAYBACKS & DISH CROSSING
SHEET 2 OF 2**

APPROVED:

PLAN No:

SD1003/2