



PENRITH CITY COUNCIL WSUD TECHNICAL GUIDELINES

**Addendum 1 – Deemed to Comply Toolkit
for Residential, Industrial
& Commercial Developments**

June 2015 (Version 1)

PENRITH
CITY COUNCIL

TABLE OF CONTENTS

1.0	INTRODUCTION	1
2.0	SUBMISSION REQUIREMENTS	2
2.1.	DA Stage	2
2.2.	CC Stage.....	2
3.0	DEEMED TO COMPLY TOOLS	3
3.1.	Residential Development.....	3
3.1.1.	Standard Treatment Measures.....	3
3.1.2.	Constrained Sites	5
3.2.	Industrial/Commercial development	5
3.2.1.	Standard Treatment Measure.....	5
3.2.2.	Constrained Sites	6
4.0	WSUD DESIGN GUIDELINES	7
4.1.	Raingardens	7
4.2.	Rainwater Tanks.....	9
4.3.	Buffer Strips.....	10
4.4.	Permeable Pavement.....	11
5.0	OPERATION & MAINTENANCE.....	12
6.0	GLOSSARY OF TERMS	13

APPENDICES

APPENDIX A

WSUD Design Checklists

APPENDIX B

Sample Operation and Maintenance Plan

APPENDIX C

Case Studies 1, 2, 3 – Residential, Industrial and Commercial Development

APPENDIX D

WSUD Standard Drawings

1.0 INTRODUCTION

Council engaged Storm Consulting Pty Ltd to prepare a set of deemed to comply options for smaller scale development.

This Deemed to Comply (DTCP) toolkit has been developed for the purpose of assisting developers and their consultants to meet Council's Water Sensitive Urban Design (WSUD) Policy.

The DTCP toolkit provides tailored WSUD solutions which account for a range of parameters such as the development site type, bypass proportion, soils, and stormwater system. A number of standard drawings and case studies utilising specific WSUD devices have been developed to demonstrate how typical developments can comply with Council's WSUD requirements.

This document should be read and applied in conjunction with Part C3 of the DCP (2010), Stormwater Drainage for Building Developments (2013) and with the latest version of Council's WSUD Technical Guidelines.

2.0 SUBMISSION REQUIREMENTS

2.1. DA Stage

Reference should be made to Council's document "Stormwater Drainage for Building Developments (2013)" for information required at DA submission. The following additional information must be submitted as part of a Development Application to fulfil Council's water quality and OSD Controls:

- The location, type, size and configuration of WSUD treatment measures selected from Section 3.0 of this toolkit. These may be prepared from standard drawings provided in Appendix D.
- The area of ground or roof areas directing stormwater runoff to each treatment measure. Areas bypassing treatment shall also be shown.
- Calculations demonstrating how Council's OSD and water quality requirements have been satisfied. Case studies of typical residential, industrial and commercial developments have been provided in Appendix C.
- The relevant treatment measure design checklist filled out as provided in Appendix A.
- A draft Operation and Maintenance Plan shall be submitted as shown in Appendix B.

2.2. CC Stage

A site specific Operation and Maintenance Plan for water quality and OSD features must be submitted with the CC. Examples of such plans can be found in Appendix B.

3.0 DEEMED TO COMPLY TOOLS

This section provides a hierarchy of water management controls for use in selected developments within the Penrith LGA. WSUD devices have been selected based on the effectiveness with removing site pollutants from residential and industrial/commercial developments.

The deemed-to-comply provisions apply to sites with a total area of less than 5,000m², and where basement car parking is not proposed. Applicants are required to adopt treatment measures from 3.1.1 and 3.2.1. Where sites are constrained and there are no alternatives i.e. flat sites with no public drainage system in the street, the following treatment measures from 3.1.2 and 3.2.2 can be adopted as a last resort.

Design guidelines of preferred WSUD devices can be found in section 4.0 while standard drawings of the WSUD devices can be found in Appendix D. Case studies have also been provided in Appendix C demonstrating how typical multi-unit housing, industrial and commercial developments can implement the WSUD measures.

3.1. Residential Development

3.1.1. Standard Treatment Measures

Roof and ground surfaces can be treated together or separately to comply with Council’s water quality targets. Table 1 presents the preferred treatment options for residential developments. Compliance with Council’s water quality targets is based on selecting the appropriate size of the treatment measure as a percentage of the impervious site area.

Table 1 – Standard Treatment Measure Options for Residential Developments

Option No.	Pollutant Source	Treatment Measure	Sizing
1a	Roof & Ground	Standard Raingarden	See Figure 3.1
1b	Roof & Ground	Standard Raingarden & 2000L Rainwater Tank (for each dwelling) connected to toilet	See Figure 3.2

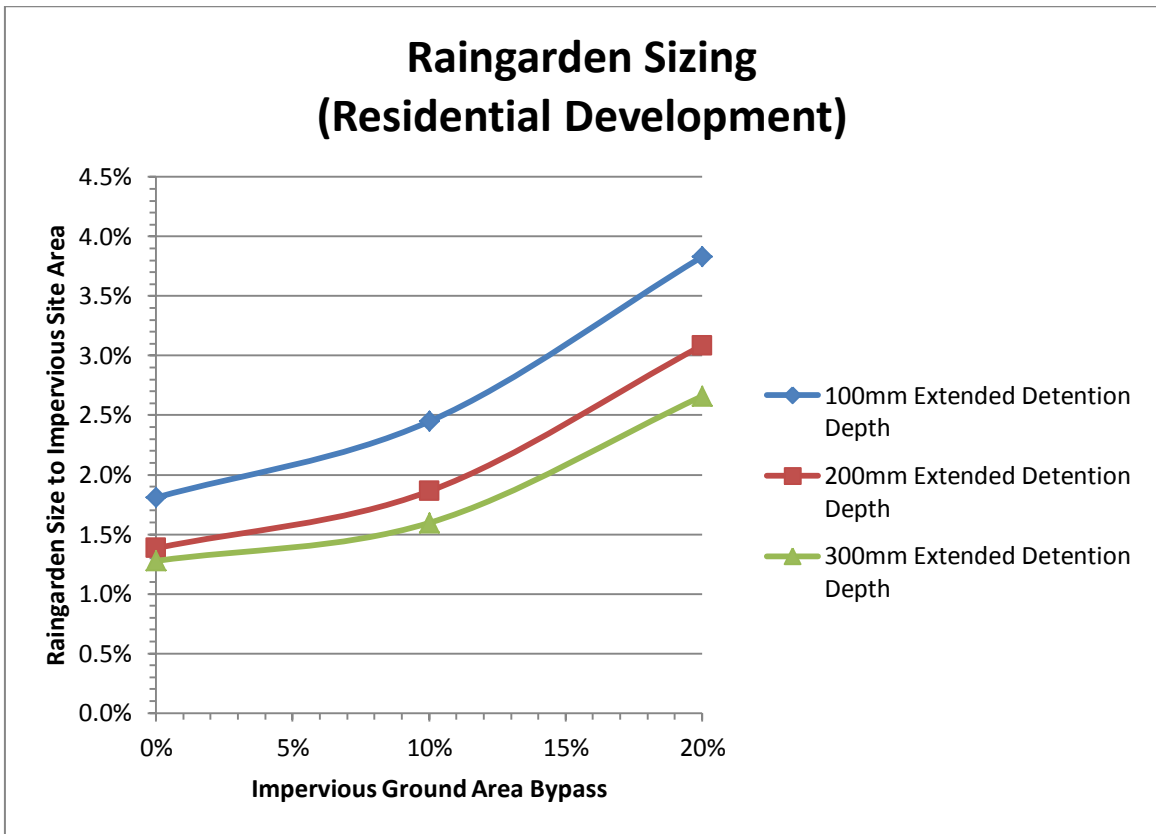

Figure 3.1 –Raingarden Filter Area Sizing for Residential Developments

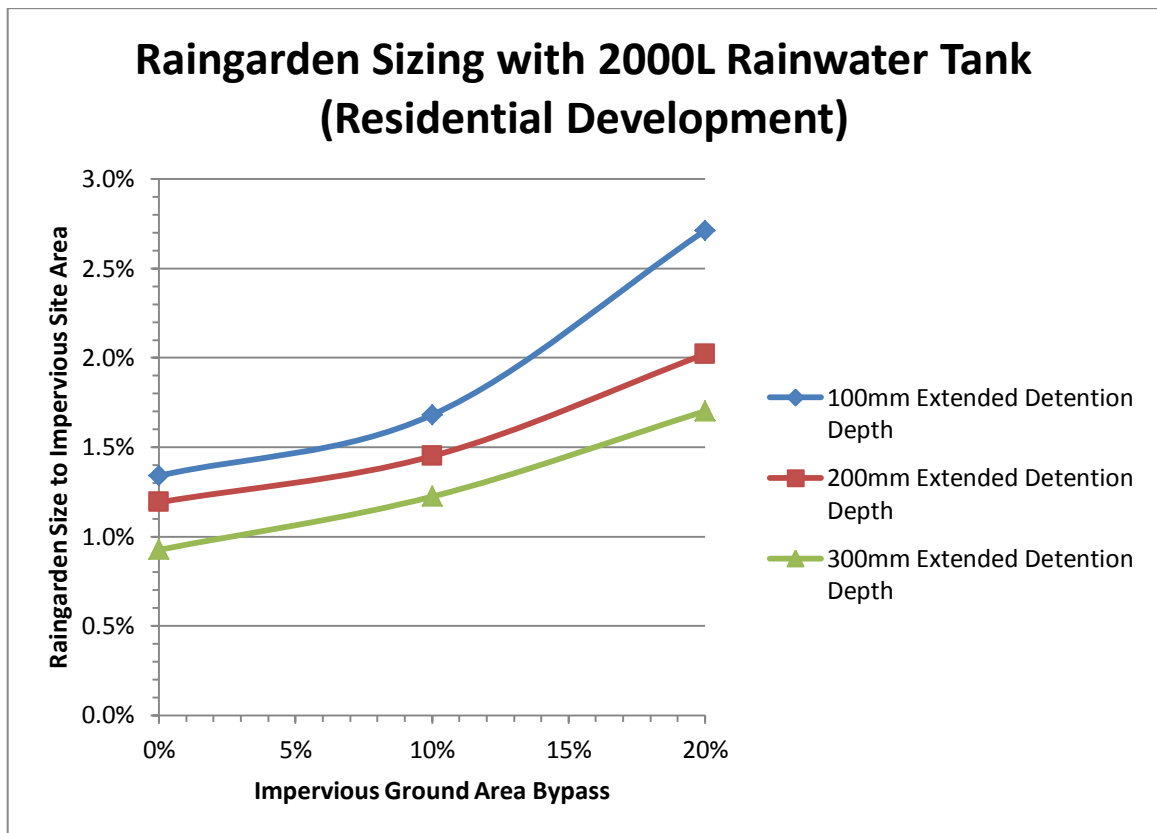

Figure 3.2 – Raingarden Filter Area Sizing with 2000L Rainwater Tank for Residential Developments

3.1.2. Constrained Sites

Where there are limitations with achieving the required grade to drain the site via a standard raingarden, a raingarden with submerged zone may be used as to achieve the required drainage levels. Table 2 presents the treatment options for a constrained residential development. Refer to section 4.3 and 4.4 for further details.

Buffer strips may be used for reducing the effective impervious area used to calculate raingarden sizes.

Table 2 – Treatment Measure Options for Constrained Residential Developments

Option No.	Pollutant Source	Treatment Measure	Sizing
1c	Roof & Ground	Raingarden with Submerged Zone	See Figure 3.1
1d	Roof & Ground	Raingarden with Submerged Zone & 2000L Rainwater Tank connected to toilet	See Figure 3.2

3.2. Industrial/Commercial development

3.2.1. Standard Treatment Measure

Table 3 presents the preferred treatment measure for treating both roof and ground areas in industrial/commercial developments. Compliance with Council's water quality targets is based on selecting the appropriate size of the treatment measure as a percentage of the impervious ground area.

Table 3 – Standard Treatment Measure for Industrial/Commercial Developments

Option No.	Pollutant Source	Treatment Measure	Sizing
2a	Roof & Ground	Standard Raingarden	See Figure 3.3

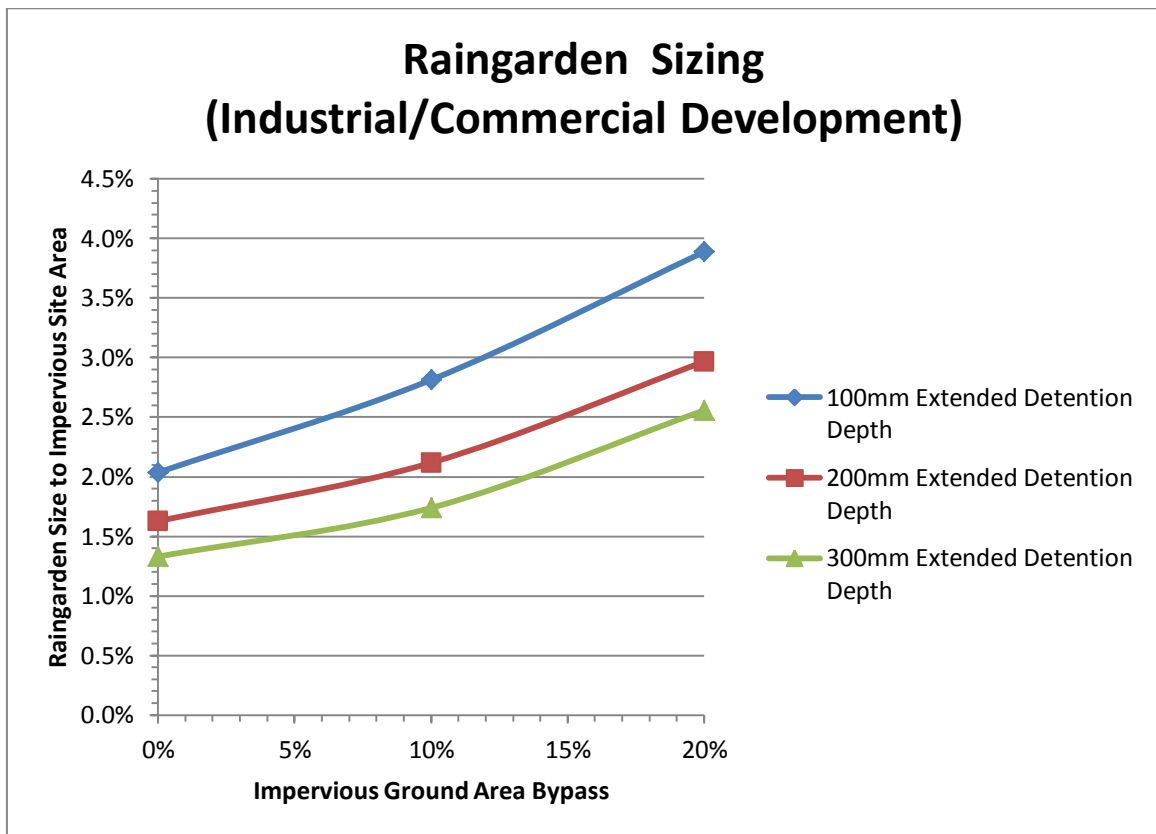

Figure 3.3 – Raingarden Filter Area Sizing for Industrial/Commercial Developments

3.2.2. Constrained Sites

Where there are limitations with achieving the required grade to drain the site via a standard raingarden, a raingarden with submerged zone may be used as to achieve the required drainage levels. Table 4 presents the alternative treatment measure for a constrained industrial/commercial development.

Buffer strips may be used for reducing the effective impervious area used to calculate raingarden sizes for commercial developments.

Table 4 – Treatment Measure for Constrained Industrial/Commercial Developments

Option No.	Pollutant Source	Treatment Measure	Sizing
2b	Roof & Ground	Raingarden with Submerged Zone	See Figure 3.3

4.0 WSUD DESIGN GUIDELINES

4.1. Raingardens

Raingardens must fulfil the following requirements to be claimed as a treatment measure:

- The entire roof area and at least 80% of the impervious ground area is treated by one or more raingardens sized using the charts in Section 3.
- Raingardens should be located upstream of OSD systems, and all treated and bypass water from the raingardens shall be directed to the OSD.
- The inflow system has rock protection to prevent surface scouring
- The top water level is at least 50mm below surrounding area
- The extended detention depth does not exceed 300mm.
- The mulch layer depth ranges from 50-75mm. The mulch layer is comprised of non-floatable stone aggregate mulch sized 20mm or similar.
- The filter media depth ranges from 450-1000mm in the standard raingarden and from 300-1000mm for raingarden with submerged zone.
- The filter media is comprised of loamy sand with a permeability of 100-300 mm/hr under compaction and a minimum orthophosphate content of 40mg/kg.
- The transition layer depth is at least 100mm. The transition layer is comprised of clean well graded sand/coarse sand.
- The drainage layer depth is at least 150mm in the standard raingarden and at least 350mm in the raingarden with submerged zone.
- The drainage layer is comprised of clean fine gravel sized 2-5 mm with 90-100 mm perforated pipes over the base of the filter.
- Flushing point(s) and an overflow pit have been installed
- The liner selected is impermeable
- Plant species have been selected in accordance with Section 6.1 of Council's WSUD Technical Guidelines and planted at a density of 8 plants/m²

Raingarden Types

Standard raingardens consist of an engineering filter media profile planted with drought tolerant species. They collect stormwater from impervious areas, trapping smaller sediments and removing nutrients in stormwater runoff prior to returning treated stormwater to the stormwater system through a slotted pipe in the base of the garden bed profile. The treated stormwater is discharged to the stormwater system by gravity.



Typical raingarden (source: www.esf.edu)

Where there is insufficient difference in levels to drain the treated water from the raingarden to the stormwater system by gravity a raingarden with submerged zone may be adopted. This arrangement retains water in the lower section of the raingarden and provides for treated stormwater to drain from the raingarden at a higher level. This type of raingarden is suitable for constrained sites.

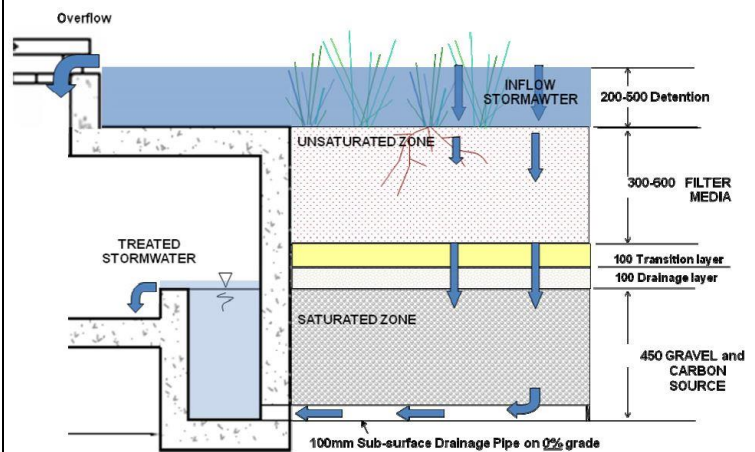

Raingarden with submerged zone
(source: www.monash.edu.au/fawb)

4.2. Rainwater Tanks

Rainwater tanks collect and store stormwater runoff from the roofs of the proposed buildings for reuse purposes such as toilet flushing and outdoor irrigation. Once rainwater tanks are filled with stormwater runoff, overflows from the tanks are directed to the downstream drainage system. Rainwater tanks must fulfil the following requirements to be claimed as a treatment measure:

- At least 50% of the roof area is connected to the rainwater tank of each dwelling
- Rainwater harvested is re-used internally for toilet flushing. Rainwater harvested may be used for other approved purposes such as laundry.
- All bypass water from rainwater tanks shall be directed to the OSD.
- An appropriate connection to mains water has been installed to supply water to tank when empty.
- Rainwater tank has been designed in accordance with the provisions of Section C3.8 Water Management in Council's DCP 2010, and SEPP (Exempt and Complying Development) 2008 including installation of safety signs and pipe labelling.
- Rainwater tank volume cannot be claimed as an offset for On-Site Stormwater Detention volume.



Figure 4.1: Rainwater tank (source: www.savewater.com.au)

4.3. Buffer Strips

Buffer strips are areas of vegetation designed to slow stormwater runoff as it travels from impervious surfaces to a discharge point. They reduce and retain sediment loads as runoff passes through the vegetation. Buffer strips rely on shallow, uniform flows to treat runoff and will be well suited for treating impervious surfaces such as driveway and foot paving areas. A set down of an adequate depth is often required to retain the build-up of accumulated sediment and prevent potential scouring. Buffer strips may be used to claim a discount in site impervious area for the purpose of calculating raingarden areas under section 3. A 50% discount can be claimed for impervious areas draining to a buffer strip subject to the following conditions:

- Filter rolls are to be placed every 5-10 metres across buffer strip during establishment
- Runoff is collected from the adjacent driveways only.
- Buffer strips should be located upstream of OSD systems, and all treated and bypass water from the buffer strips shall be directed to the OSD. The inlet flows are uniformly distributed into the swale. Alternatively, wheelstrips may be used along the driveway.
- Longitudinal slope ranging from 1 - 3 %.
- Buffer strip vegetation is set down of at least 50mm below edge of driveway
- Where used, mulch must be non-floatable 20mm gravel or similar
- Batter grades are less than 1:6 for turf and less than 1:4 for landscape areas
- Collection pits drain 100m² of catchment every 20m of buffer strip
- Top soils are a minimum depth of 300mm for plants and 100mm for turf



Figure 4.2: Buffer Strips (source: www.lindenlandgroup.com)

4.4. Permeable Pavement

Permeable pavements are porous surfaces which overlay an aggregate layer of crushed stone or gravel. Stormwater runoff passes through the permeable pavement to the aggregate layer before it is discharged to a piped drainage system. This process reduces the peak flow site runoff by delaying time for water to enter drainage system and improves the quality of stormwater runoff by removing site pollutants.

Permeable paving may be used subject to the following conditions:

- Permeable paving is only used within areas of carparking or pedestrian pathways. This does not include driveway and OSD areas.
- Permeable paving is graded towards a piped drainage system so that runoff is controlled where a rainfall event exceeds the infiltration rate of the pavement.
- Where permeable paving is located upstream of OSD systems, all treated and bypass water from the permeable paving shall be directed to the OSD.
- The permeable pavement provided must be a hard stand material or bonded asphaltic material such as pervious concrete. Council does not permit loose aggregate style permeable pavement such as road base or gravel type material.
- Certification and standard drawings of the permeable paving must be provided. The certification shall demonstrate that the permeable paving is suitable for its intended use (i.e withstands the loads from cars, etc)



Figure 4.3: Permeable pavement (source: www.blogs.scientificamerican.com)

5.0 OPERATION & MAINTENANCE

Operation and maintenance of treatment systems are straightforward, being similar to maintenance of standard gardens and drainage infrastructure.

Following the construction of treatment measures, they should be inspected every 1 to 3 months and inspected after each major rainfall event for the initial establishment period to determine whether immediate maintenance is needed. Residents will need to be aware of the functions and benefits associated with the treatment measures so that it is looked after and not damaged or misused.

Initial establishment periods are typically:

- 1 month for rainwater tanks
- 1 to 2 years for raingardens
- 1 to 2 years for buffer strips

After the initial establishment period, inspection of the treatment measures may be extended to the frequencies shown in sample operation and maintenance plans in Appendix B.

6.0 GLOSSARY OF TERMS

(Adapted from Queensland Urban Drainage Manual, 2008)

Raingarden	A well-vegetated retention cell or pond designed to enhance water filtration through a specially prepared sub-surface sand filter. The system incorporates vegetation with medium-term stormwater retention and sub-surface filtration/infiltration.
Bypass Flow	The portion of flow from a site which drains to Council's drainage system without first going through OSD or water quality treatment.
Drainage System	A system of inlet pits, pipes, overland flow paths, open channels, culverts and detention basins used to convey runoff to its receiving waters.
Detention	The process of holding water in a control structure for a limited period of time and releasing it at a reduced rate over long period of time.
Overland Flow Path	Where a piped drainage system exists: it is the path where storm flows in excess of the capacity of the underground drainage system would flow. Where no piped drainage system or other form of defined watercourse exists: it is the path taken by surface runoff from higher parts of the catchment to a watercourse, channel or gully. It does not include a watercourse, channel or gully with well defined bed and banks.
Stormwater	Rainfall that collectively runs off all urban surfaces such as roofs, pavements, car park areas, roads, gardens and vegetated open space.
Water Sensitive Urban Design (WSUD)	A set of design elements and on-ground solutions that aim to minimise impacts on the water cycle from the built urban environment. It offers a simplified and integrated approach to land and water planning by dealing with the urban water cycle in a decentralised manner consistent with natural hydrological and ecological processes.

APPENDIX A

WSUD Design Checklists

WSUD DEVELOPMENT ASSESSMENT CHECKLIST

1. SITE INFORMATION

Address:

Development Type

DA No:

Total Site Area (m²):

Impervious Ground Area (m²):

Roof Area (m²):

Reduction in Impervious area (m²):

Net Impervious Area (m²):

2. WATER MANAGEMENT CONTROLS

a) Proposed treatment measures:

Raingarden Rainwater Tank Buffer Strip Permeable paving Other

b) Proposed treatment measures shown on plan?

Y / N

3. TREATMENT OPTIONS

Proposed Treatment Measure	Catchment (%)	Catchment Size (m ²)	Treatment Measure Size (m ²)
a)			
b)			
c)			
d)			

3. DOCUMENTATION

a) Design checklist submitted for each treatment measure?

Y / N

b) Operation and Maintenance Plan submitted for each treatment measure?

Y / N

COMMENTS

RAINGARDEN DESIGN CHECKLIST

Location:	DA No:
Catchment Area (ha):	Filter Media Area (m ²):
1. INFLOW SYSTEM	
a) Roof area and at least 80% of the impervious ground area treated by the standard raingarden or raingarden with submerged zone at the front setback?	Y / N
b) Inlet scour protection provided at inflow locations?	Y / N
2. RAINGARDEN CONFIGURATION	
a) Top water level \geq 50mm below surrounding area?	Y / N
b) Extended detention depth \leq 300mm for standard raingarden or raingarden with submerged zone?	Y / N
c) Mulch layer depth ranges from 50-75mm comprised of non-floatable stone aggregate mulch sized 10-20mm?	Y / N
d) Filter media depth ranges from 450-1000mm for standard raingarden, from 300-1000mm for raingarden with submerged zone?	Y / N
e) Filter media is comprised of loamy sand with a permeability of 100-300 mm/hr under compaction and a minimum orthophosphate content of 40mg/kg?	Y / N
f) Transition layer depth \geq 100mm and comprised of clean well graded sand/coarse sand?	Y / N
g) Slotted 90-100mm dia pipes provided within drainage layer?	Y / N
h) Drainage layer \geq 350mm for raingarden with submerged zone or \geq 150mm for standard raingarden?	Y / N
i) Liner type selected is impermeable?	Y / N
j) Flushing point provided?	Y / N
k) Overflow pit provided?	Y / N
3. VEGETATION DESIGN	
a) Species selected in accordance with Section 6.1 of Council's WSUD Technical Guidelines?	Y / N
b) Planting density \geq 8 plants / m ² ? (Shrubs or trees may be included)	Y / N
COMMENTS	

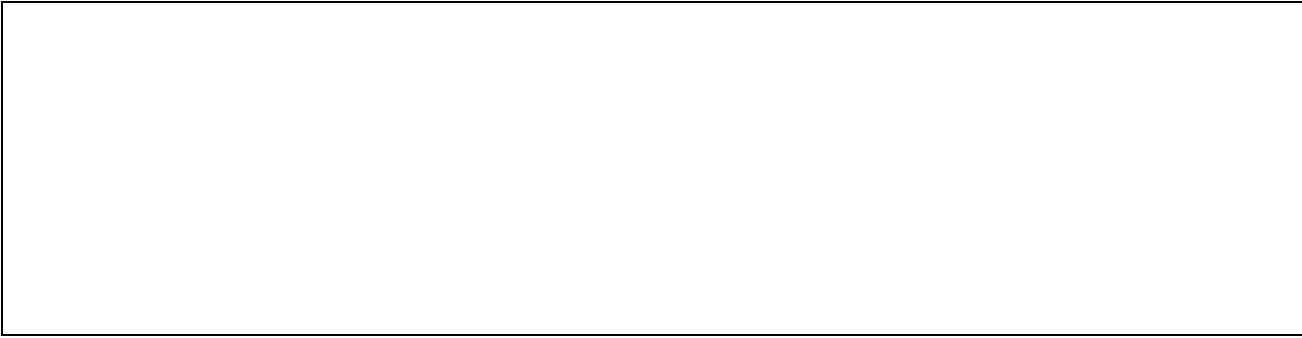

RAINWATER TANK DESIGN CHECKLIST

Location:	DA No:
Catchment Area (ha):	Rainwater Tank Capacity (L):
1. RAINWATER TANK CONFIGURATION	
a) Rainwater tank capacity specified?	Y / N
b) At least 50% of the roof area diverts runoff to rainwater tank?	Y / N
c) Connected to the following for internal re-use: <input type="checkbox"/> No of toilets: _____ <input type="checkbox"/> Laundry <input type="checkbox"/> Other: _____	Y / N
d) Fitted with a first-flush device?	Y / N
e) Connection to mains water has been installed to supply water to tank when empty?	Y / N
e) Will not exceed 3 metres in height above ground level (including stand)?	Y / N
f) Will not rest on a footing of any building or other structure on the property including retaining wall?	Y / N
COMMENTS	

BUFFER STRIP DESIGN CHECKLIST

Location:	DA No:
Catchment Area (ha):	Buffer Strip Area (m ²):
1. INFLOW SYSTEM	
a) Inlet flows uniformly distributed?	Y / N
b) Buffer strip vegetation set down of at least 50mm below driveway edge?	Y / N
2. BUFFER STRIP CONFIGURATION	
a) Batter grades <1:6 for turf or <1:4 for landscape areas?	Y / N
b) Longitudinal slope ranges from 1-3%?	Y / N
c) Collection pit provided to drain 100m ² of catchment every 20m?	Y / N
3. LANDSCAPE	
a) Top soils are a minimum depth of 300mm for plants and 100mm for turf?	Y / N
b) Plant species selected can tolerate periodic inundation and design velocity?	Y / N
COMMENTS	

APPENDIX B

Sample Operation and Maintenance Plan

SAMPLE RAINGARDEN MAINTENANCE PLAN

Location:		DA No:
INSPECTION ITEMS	FREQUENCY	ACTION REQUIRED
Mulch	3 months	Replace mulch as needed with a material that will not float away
Surface vegetation	6 months	<ul style="list-style-type: none"> ▪ Inspect health of plants and trim where necessary ▪ Remove and replace diseased/dead plants with same species ▪ Remove weeds
Debris/sediment	6 months	Inspect and clean debris/sediment build-up from surface, inlet area and overflow.
Ponding	6 months	If ponding occurs for more than 3 days after storms, check whether underdrain or filter media is blocked
Outlet/overflow pit	Yearly	Repair where cracking or spalling of concrete surfaces is identified
Underdrainage	5 years	Flush underdrainage
Filter media	~30 years	Replace filter media
COMMENTS		

SAMPLE RAINWATER TANK MAINTENANCE PLAN

Location:		DA No:
INSPECTION ITEMS	FREQUENCY	ACTION REQUIRED
First flush device	1-3 months	Inspect and clean first flush device from debris
Contamination (Mosquito/vermin breeding or algae growth)	1-3 months	Disinfection of tank
Inlet/Outlet screen	6 months	Remove leaves and debris on surface
Roof gutters	6 months	Remove leaves and debris in gutters
Pump/strainer	6 months	Inspect and clean pump/strainer from debris
Tank structure	2 years	Check footings and fittings for signs of corrosion
Depth of sediment within tank	5 years	Desludge tank by engaging a professional tank cleaner
COMMENTS		

SAMPLE BUFFER STRIP MAINTENANCE PLAN

Location:		DA No:
INSPECTION ITEMS	FREQUENCY	ACTION REQUIRED
Inlet/outlet drainage points	6 months	Remove accumulated sediment deposits, debris and litter
Surface vegetation	6 months	<ul style="list-style-type: none"> ▪ Inspect health of vegetation and trim where necessary ▪ Remove and replace diseased/dead vegetation ▪ Remove weeds ▪ Mow if grassed
Excessive shading	6 months	Prune and remove brushy vegetation on adjacent slopes
Erosion/scouring	6 months	For bare areas less than 300mm wide, repair the damaged area by filling with crushed gravel. If bare areas are large, generally greater than 300mm wide, the buffer strip should be re-graded and re-seeded.
Ponding	6 months	Remove sediment or trash blockages
COMMENTS		

PERMEABLE PAVEMENT MAINTENANCE CHECKLIST

Location:		DA No:
INSPECTION ITEMS	FREQUENCY	ACTION REQUIRED
Pavement surface	3 months	<ul style="list-style-type: none"> ▪ Clean debris and sediment build-up by sweeping/vacuum sweep
Nuisance vegetation growth	3 months	Remove weeds from pavement and replace missing sand or gravel between pavers as needed.
Ponding	3 months	<ul style="list-style-type: none"> ▪ Inspect subdrain outlets (if applicable) to verify they are not blocked. ▪ Replace clogged pavement
Pavement surface	5 years	<ul style="list-style-type: none"> ▪ Repair pavement where potholes or cracking of pavement exist ▪ Rectify pavement levels where pavement deflection is identified
COMMENTS		

APPENDIX C

Case Studies 1, 2, 3 –
Residential, Industrial and
Commercial Development

Introduction

Council’s DCP and associated policies require developments to comply with water quality and On-site Stormwater Detention (OSD) controls. To simplify this process for smaller developments, Council has developed a “deemed-to-comply” procedure which allows developers to select from a

hierarchy of water management measures to satisfy the controls.

This case study guides you through the application of this “deemed-to-comply” approach to a typical Multi-Unit Residential Development within Penrith.

Site Layout

The site has an area of 1050m² and is currently occupied by a single dwelling towards the street frontage, and a large backyard. The site falls from the rear towards the street frontage at approximately 0.8% grade.

The key areas in the proposed development are:

Total site area = 1050m²

- Roof = 386m² (36.8% of site)
- Driveway = 310m² (29.5% of site)
- Carpark = 80m² (7.6% of site)
- Footpath = 70m² (6.7% of site)
- Garden = 24m² (2.3% of site)
- Turf = 180m² (17.1% of site)

Five new housing units have been proposed on the site, each with an attached single garage and second open carparking space. A common driveway will run along one side boundary.

The overall site layout is given in Figure C.1.

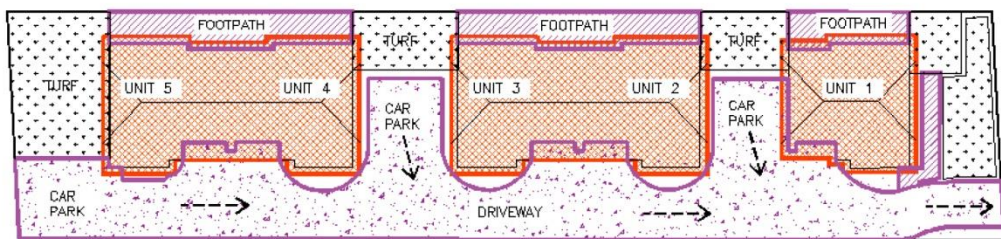

Figure C.1 - Overall Site Layout

- IMPERVIOUS GROUND AREA = 460m²
- IMPERVIOUS ROOF AREA = 386m²

Potential treatment measures

Under Council’s deemed-to-comply toolkit, roof and ground surfaces (such as driveways) can be treated together or separately in residential developments. The deemed-to-comply toolkit provides a hierarchy

of treatment measure options based on whether the site is categorised as standard or constrained. For the purpose of this case study, an excerpt is shown below for an unconstrained site treating roof and ground surfaces separately.

Treatment Measure	Pollutant Source	Sizing
Standard Raingarden (100mm extended detention depth - EDD) & 2000L Rainwater Tank connected to toilet	Roof & Ground	See Figure 3.2

Adopted solution

It was found the most effective solution for treating the roof surface was to install rainwater tanks to each unit, connected to the toilets for internal re-use. Overflows will be directed to an OSD system in the front setback. 2000L rainwater tanks have been allocated to each unit to collect runoff from the site roof area of 386m².

The driveway of 310m² was graded to the front setback to direct runoff to the raingarden prior to draining into the OSD. The site drainage system has been designed to bypass the low flows along a kerb on the edge of the driveway so these flows preferentially enter the raingarden. The pits in the driveway are set off from the kerb so that in higher flows water will begin to flow into the piped system, bypassing the raingarden.

An above ground OSD has been provided at the front setback to capture a majority of the site runoff. Under Council's OSD guidelines the site needs to provide 29m³ of OSD storage - this includes an additional of 15% OSD volume for landscaped storage areas greater than 25m³. The following treatment measures satisfy this requirement:

- Driveway bypass = 22m² (4.8% of impervious ground area, see Figure C.1)
- Impervious site area = 460 + 386 = 846m²
- Raingarden size to impervious site area = 1.45% (100mm EDD and 4.8% bypass)

- Standard raingarden size = 12.3m²
- Above ground OSD area = 60m²
- Above ground OSD storage = 30m³ (detention depth of 500mm)

OSD storage provided = 30m³ > 29m³

By using the combination of 2000L rainwater tanks and a standard raingarden to treat the multi-unit development, Council's water quality and On-Site Detention controls have been satisfied.

The new site layout is shown in Figure C.2. Key areas of the proposed development are now:

Total site area = 1050m²

- Roof = 386m² (36.8% of site)
- Driveway = 310m² (29.5% of site)
 - ❖ Driveway to OSD = 288m²
 - ❖ Bypass = 22m²
- Carpark = 80m² (7.6% of site)
- Remaining footpath = 61m² (5.8% of site)
- Remaining garden = 20.7m² (2.0% of site)
- Raingarden = 12.3 m² (1.1% of site)
 - ❖ Footpath converted to RG = 9m²
 - ❖ Garden converted to RG = 3.3m²
- Remaining turf = 120m² (11.5% of site)
 - ❖ Turf converted to OSD = 60m²
- Above ground OSD = 60m² (5.7% of site)

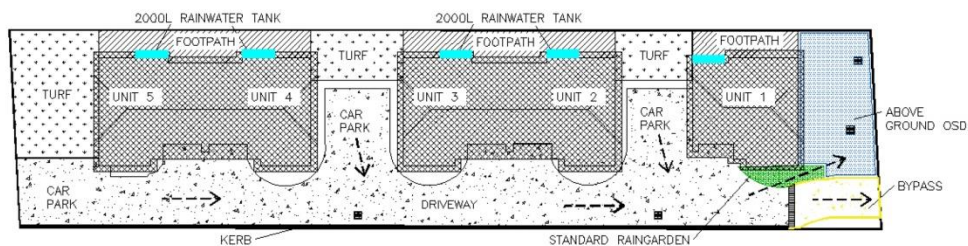

Figure C.2 – Overall Site Layout with OSD and Water Quality Controls

Introduction

Council’s DCP and associated policies require developments to comply with water quality and On-site Stormwater Detention (OSD) controls. To simplify this process for smaller developments, Council has developed a number of “deemed-to-comply” options which allow developers to select

from a specific list of water management measures that satisfy the controls.

This case study guides you through the application of this “deemed-to-comply” approach to a typical Industrial Development within Penrith.

Site Layout

The site has an area of 4000m² and is currently categorised as Greenfield land. The site falls from the rear towards the street frontage at approximately 2.5% grade.

Four new warehouse units have been proposed on the site with 8 carparking spaces allocated to each unit. A common hardstand area will run along the entire frontage, permitting vehicle access from two separate entry points.

The key areas in the proposed development are:

Total site area = 4000m²

- Roof = 2160m² (54% of site)
- Hardstand = 924m² (23.1% of site)
- Carpark = 580m² (14.5% of site)
- Turf = 336 m² (8.4% of site)

The overall site layout is given in Figure C.3.

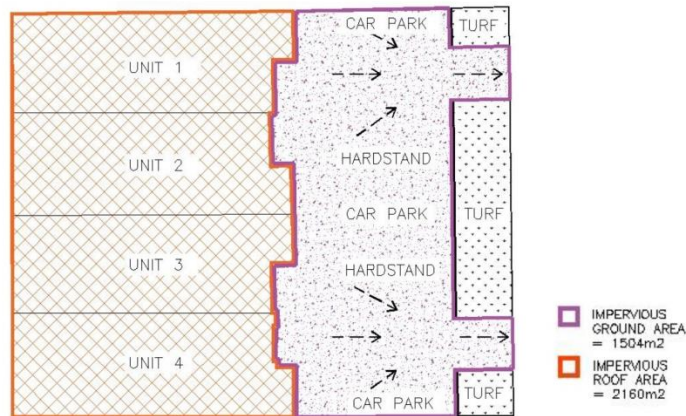

Figure C.3 - Overall Site Layout

Potential treatment measures

Under Council’s deemed-to-comply toolkit, roof areas and ground surfaces (such as driveways) are to be treated together in industrial developments. The deemed-to-comply toolkit provides a hierarchy of treatment measure options based on whether the

site is categorised as standard or constrained. For the purpose of this case study, an excerpt is shown below for a constrained site treating roof and ground surfaces together.

Treatment Measure	Pollutant Source	Sizing
Raingarden with Submerged Zone (200mm extended detention depth - EDD)	Roof & ground	See Figure 3.3

Adopted solution

The driveway of 1504m² was graded to the front setback to direct runoff to the raingarden prior to draining into the OSD. The site drainage system has been designed to bypass the low flows along a broken kerb line so these flows preferentially enter the raingarden. The pits along the hardstand are set off at low points away from the kerb so that a majority of hardstand runoff can be captured and directed into the raingarden. The roof surface, totally 2160m², directs runoff into the same pits along the hardstand connecting to the raingarden.

An above ground OSD has been provided at the front setback to capture all site runoff. Under Council's OSD guidelines the site needs to provide 128.8m³ of OSD storage - this includes an additional of 15% OSD volume for landscaped storage areas greater than 25m³. The following treatment measure satisfies this requirement:

- Driveway bypass = 128m² (8.5% of impervious ground area, see Figure C.3)
- Impervious site area = 1504 + 2160 = 3664m²
- Raingarden size to impervious site area = 2.0% (200mm EDD and 8.5% bypass)
- Raingarden with submerged zone size = 73.3m²
- Above ground OSD area = 170m²
- Above ground OSD storage = 129.2m³ (detention depth of 760mm)

OSD storage provided = 129.2m³ > 128.8m³

By using a raingarden with submerged zone to treat the industrial development, Council's water quality and On-Site Detention controls have been satisfied.

The new site layout is shown in Figure C.4. Key areas of the proposed development are now:

Total site area = 4000m²

- Roof = 2160m² (54% of site)
- Hardstand = 924m² (23.1% of site)
 - ❖ Hardstand to OSD = 796m²
 - ❖ Bypass = 128m²
- Carpark = 580m² (14.5% of site)
- Remaining turf = 92.7m² (2.3% of site)
 - ❖ Turf converted to OSD = 170m²
 - ❖ Turf converted to RG = 73.3m²
- Raingarden = 73.3m² (1.8% of site)
- OSD = 170m² (4.3% of site)

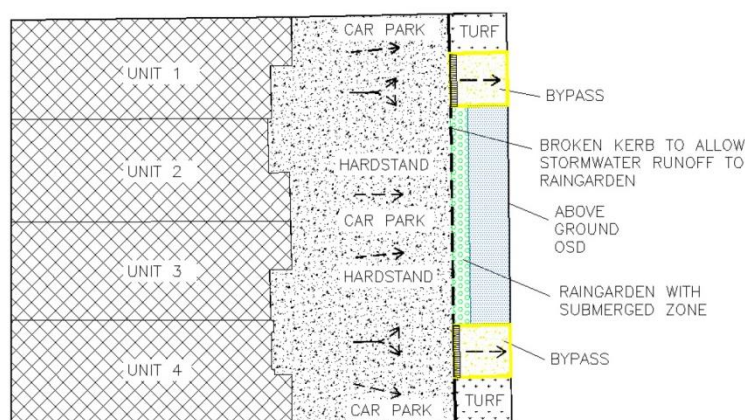

Figure C.4 – Overall Site Layout with Water Quality Controls

Introduction

Council’s DCP and associated policies require developments to comply with water quality and On-site Stormwater Detention (OSD) controls. To simplify this process for smaller developments, Council has developed a “deemed-to-comply” procedure which allows developers to select from a

hierarchy of water management measures to satisfy the controls.

This case study guides you through the application of this “deemed-to-comply” approach to a typical Commercial Development within Penrith.

Site Layout

This site has an area of 1290m² and is currently occupied by a single office building towards the street frontage, and a large backyard. The site falls from the rear towards the street frontage at approximately 1.5% grade.

A new office building has been proposed towards the rear of the site with 14 new carparking spaces to facilitate both office buildings on the site. A common hardstand area will run along the majority of the site, permitting vehicle access from a separate entry and exit point.

The key areas in the proposed development are:

Total site area = 1290m²

- Roof = 480m² (37.2% of site)
- Hardstand = 476m² (36.9% of site)
- Carpark = 264m² (20.5% of site)
- Turf = 14m² (1.1% of site)
- Garden = 56m² (4.3% of site)

The overall site layout is shown in Figure C.5.

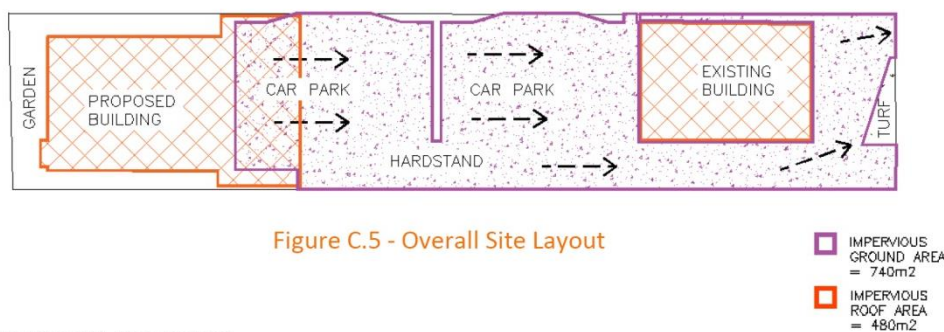

Potential treatment measures

Under Council’s deemed-to-comply toolkit, roof areas and ground surfaces (such as driveways) are to be treated together in commercial developments. The deemed-to-comply toolkit provides a hierarchy of treatment measure options based on whether the

site is categorised as standard or constrained. For the purpose of this case study, an excerpt is shown below for a standard site treating roof and ground surfaces together.

Treatment Measure	Pollutant Source	Sizing
Standard Raingarden (300mm extended detention depth - EDD)	Ground	See Figure 3.5

Adopted solution

The hardstand area of 740 m² was divided into two sections, grading to separate raingardens prior to draining into the OSD. The site drainage system has been designed to bypass the low flows along a kerb on the edge of the driveway so these flows preferentially enter the raingarden. The pits in the driveway are set off from the kerb so that in higher flows water will begin to flow into the piped system, bypassing the raingarden.

Permeable paving has been installed across two sections of the hardstand area, approximately 58m² each. These sections will be used for carparking only.

A below ground OSD has been provided at the front setback to capture site runoff. Under Council's OSD guidelines the site needs to provide 36.2m³ of underground OSD storage. The following treatment measures satisfy this requirement:

- Driveway bypass = 44.5m² (6% of impervious ground area, see Figure C.5)
- Impervious site area = 740 + 480 = 1220m²
- Raingarden size to impervious site area = 1.55% (300mm EDD and 6% bypass)
- Standard raingarden size = 18.9m²
- Below ground OSD area = 38m²

- Below ground OSD storage = 36.8m³ (based on a detention depth of 920mm)

OSD storage provided = 36.8m³ > 36.2m³

By combining 2000L rainwater tanks and a standard raingarden to treat the commercial development, Council's water quality and On-Site Detention controls have been satisfied.

The new site layout is shown in Figure C.6. Key areas of the proposed development are now:

Total site area = 1290m²

- Roof = 480m² (37.2% of site)
- Hardstand = 476m² (36.9% of site)
 - ❖ Hardstand to OSD = 431.5m²
 - ❖ Bypass = 44.5m²
- Carpark = 264m² (20.5% of site)
 - ❖ Carpark to OSD = 148m²
 - ❖ Permeable Paving = 116m²
- Remaining turf = 0m²
- Remaining garden = 51.1m² (3.9% of site)
- Raingarden = 18.9m² (1.5% of site)
 - ❖ Turf converted to RG = 14.0m²
 - ❖ Garden converted to RG = 4.9m²
- Underground OSD = 38m² (2.9% of site)

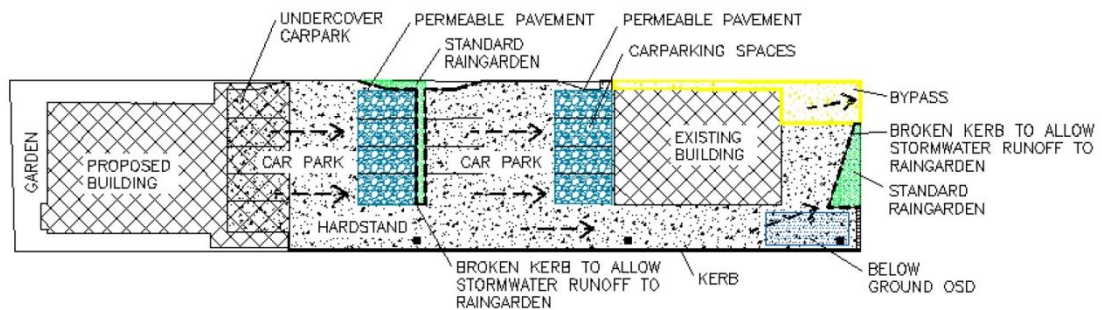
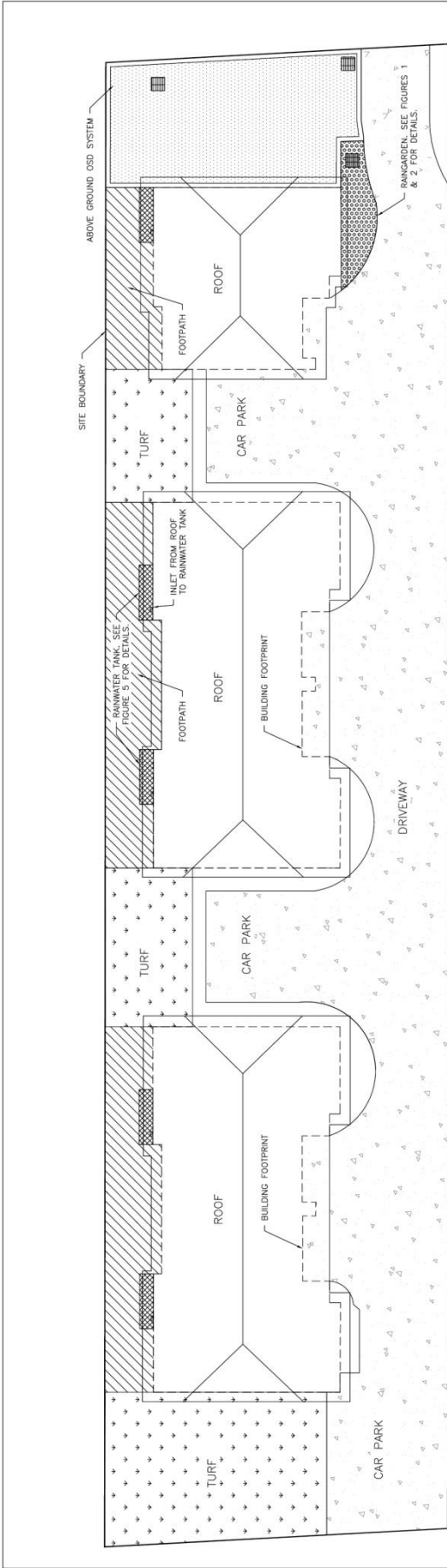

Figure C.6 – Overall Site Layout with Water Quality Controls

APPENDIX D

WSUD Standard Drawings



TYPICAL SITE LAYOUT
SCALE 1:250

PRE-DEVELOPMENT SITE AREA MATRIX

- ROOF = 386m² (36.8% OF SITE)
- DRIVEWAY = 310m² (29.5% OF SITE)
- CARPARK = 80m² (7.6% OF SITE)
- FOOTPATH = 70m² (6.7% OF SITE)
- GARDEN = 24m² (2.3% OF SITE)
- TURF = 180m² (17.1% OF SITE)

TOTAL IMPERVIOUS AREA = 846m² (80.6% OF SITE)
TOTAL PERVIOUS AREA = 204m² (19.4% OF SITE)

TOTAL SITE AREA = 1050m²

STORMWATER TREATMENT CALCULATIONS

DRIVEWAY BYPASS = 22m² / 1050m² = 4.8%
200L RAINWATER TANK PROVIDED TO EACH DWELLING
RAINGARDEN SIZE TO IMPERVIOUS SITE AREA = 1.45%
100mm EDD AND 8% BYPASS, FIGURE 3.2
STANDARD RAINGARDEN SIZE = 846m² * 1.45% = 12.3m²
TOTAL RAINGARDEN SIZE = 12.3m²

ON-SITE DETENTION CALCULATIONS

SSR REQUIRED = 240m³/ha (MULTI-UNIT HOUSING)
OSD REQUIRED = 1050m² * (240/10000) * 1.15 = 29m³
(ABOVE GROUND STORAGE SYSTEM)
OSD PROVIDED = 60m² x 500mm = 30m³
TOTAL ABOVE GROUND OSD VOLUME = 30m³

POST-DEVELOPMENT SITE AREA MATRIX

- ROOF = 386m² (36.8% OF SITE)
- DRIVEWAY = 310m² (29.5% OF SITE)
 - * DRIVEWAY TO OSD = 288m²
 - * BYPASS = 22m²
- CARPARK = 80m² (7.6% OF SITE)
- REMAINING FOOTPATH = 61m² (5.8% OF SITE)
- REMAINING GARDEN = 20.7m² (2.0% OF SITE)
- RAINGARDEN = 12.3m² (1.1% OF SITE)
 - * FOOTPATH CONVERTED TO RG = 9m²
 - * GARDEN CONVERTED TO RG = 3.3m²
- REMAINING TURF = 120m² (11.5% OF SITE)
 - * TURF CONVERTED TO OSD = 60m²
- ABOVE GROUND OSD = 60m² (5.7% OF SITE)

TOTAL IMPERVIOUS AREA = 837m² (79.7% OF SITE)
TOTAL PERVIOUS AREA = 213m² (20.3% OF SITE)

TOTAL SITE AREA = 1050m²



2.5 1.25 0 2.5 5 1:250
Original sheet size A4



North

SYDNEY

SUITE 18, 12 TRYON RD, LINDFIELD, NSW 2070

P 02 9499 4333

WSUD DRAWINGS - TYPICAL DA SUBMISSION

Date 30.04.15

Figure 01

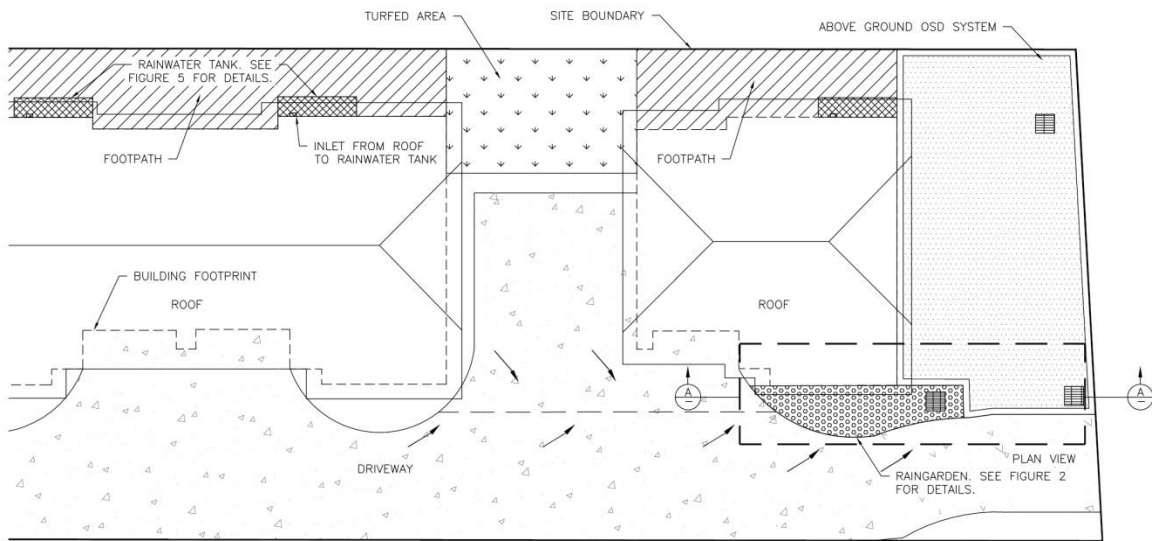

TYPICAL SITE LAYOUT

SCALE 1:200

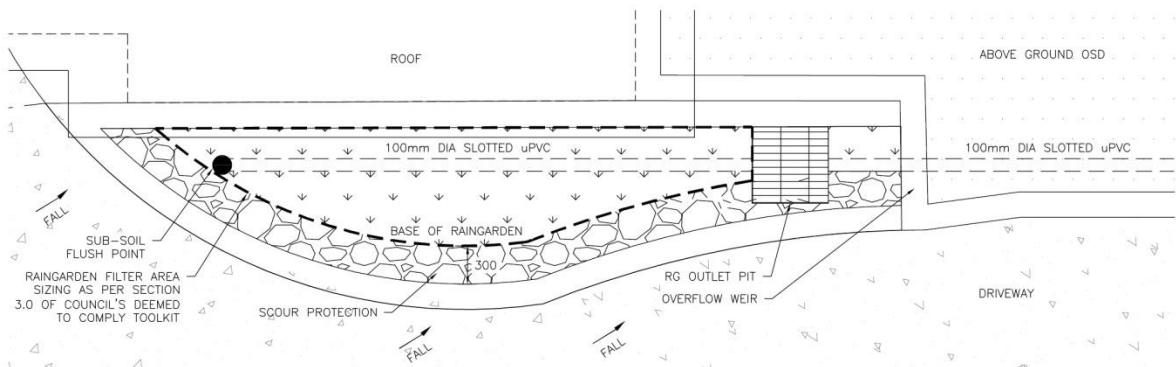

PLAN VIEW

SCALE 1:50

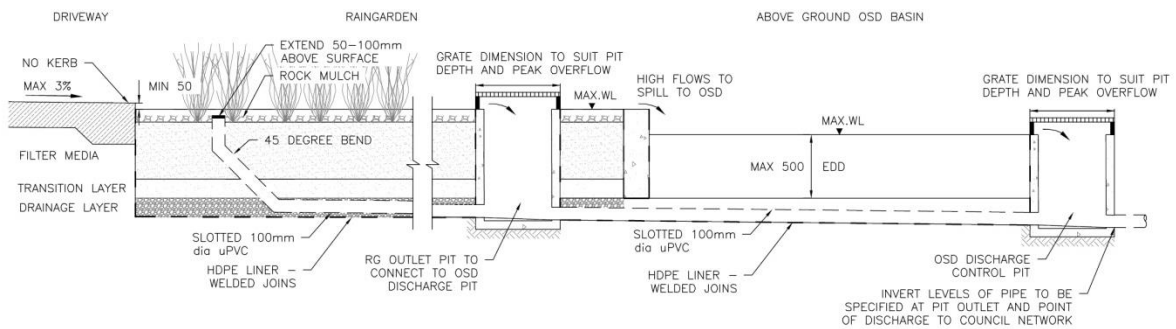

SECTION A

SCALE 1:50

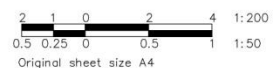

WSUD DRAWINGS - SITE LAYOUT

Date 30.04.15

DEEMED TO COMPLY TOOLKIT - Figure 2

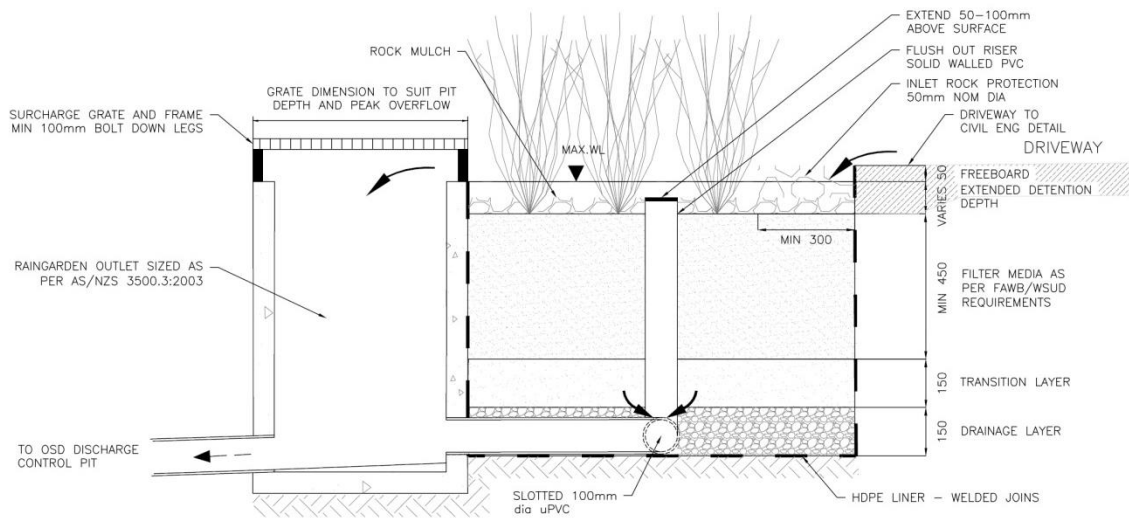

STANDARD RAINGARDEN

SCALE 1:20

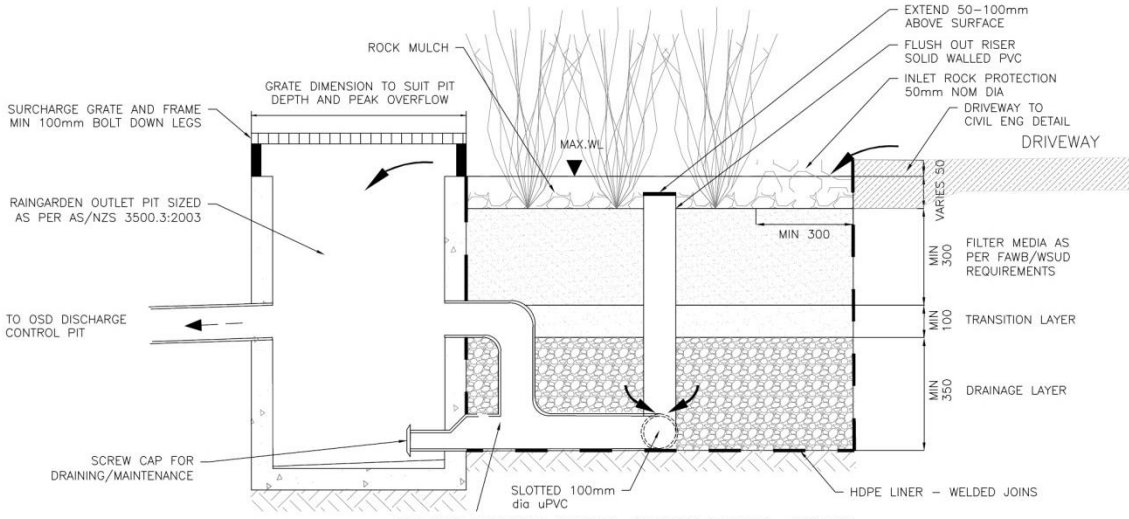

RAINGARDEN WITH SUBMERGED ZONE

SCALE 1:20

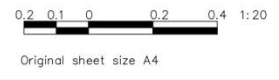

WSUD DRAWINGS - RAINGARDENS

Date 30.04.15

DEEMED TO COMPLY TOOLKIT - Figure 3

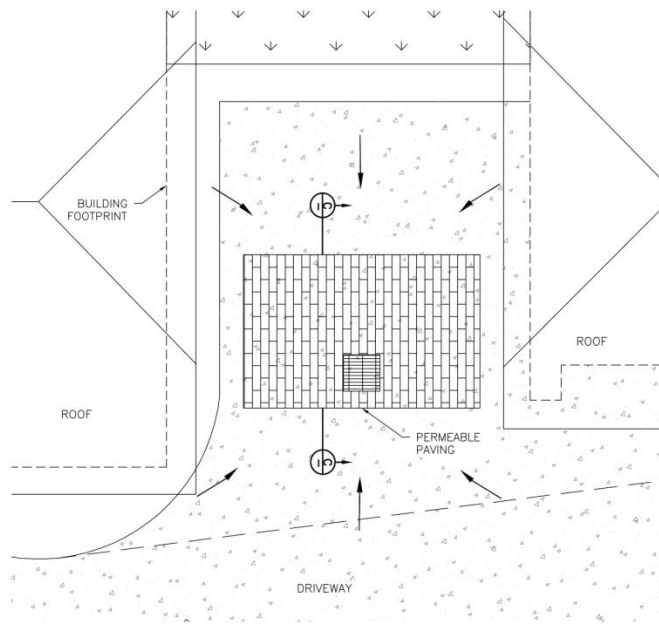

TYPICAL PERMEABLE PAVEMENT

SCALE 1:100

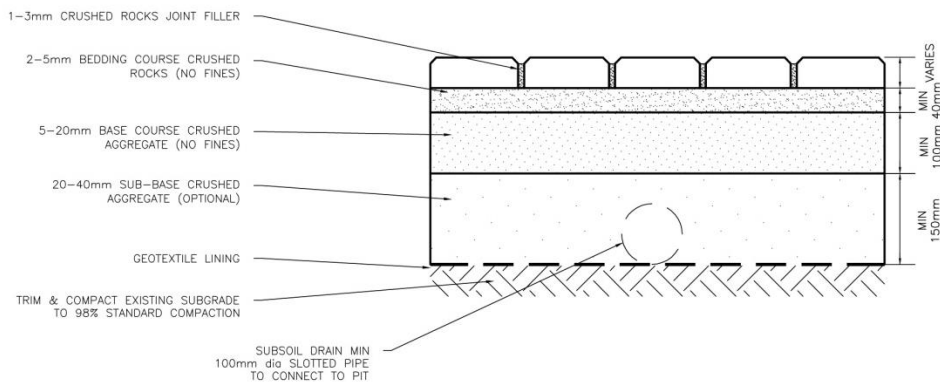

SECTION C

SCALE 1:10

NOTE: BEDDING LAYER DEPTHS VARY FROM PRODUCT TO PRODUCT AND SHOULD BE ADJUSTED TO SUIT MANUFACTURERS SPECS AND TRAFFIC LOADING.

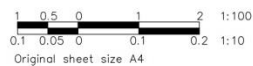

WSUD DRAWINGS - PERMEABLE PAVING

Date 30.04.15

DEEMED TO COMPLY TOOLKIT - Figure 5

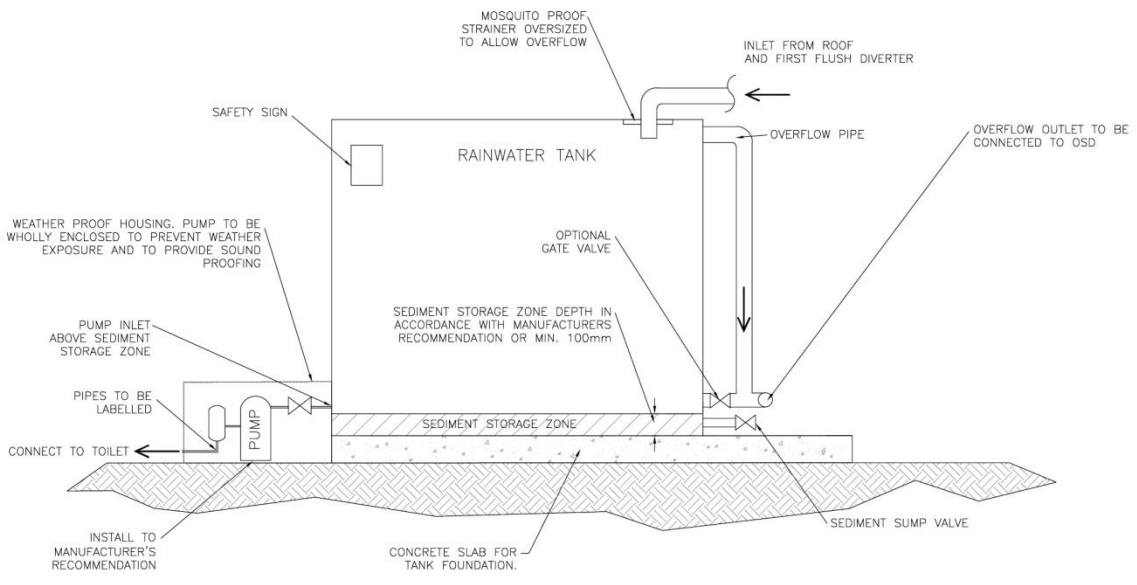

RAINWATER TANK
SCALE 1:200

NOTE: AN APPROPRIATE CONNECTION TO MAINS WATER SHALL BE INSTALLED TO SUPPLY WATER TO TANK WHEN EMPTY.



WSUD DRAWINGS - RAINWATER TANK

Date 30.04.15

DEEMED TO COMPLY TOOLKIT - Figure 6